

ITEM NO.	QTY	PART NUMBER	DESCRIPTION	WEIGHT (LBS)	RSPL CODE	RSPL QTY	SHOW (Y/N)
1	1	30678077	HEATER,FORCED AIR (180W, 220 VAC, 5MM TUBE, FOR ROPEX)	0.000			N
2	1	30683930	LABEL, CLOSED LOOP LAP SEAL	0.014			N

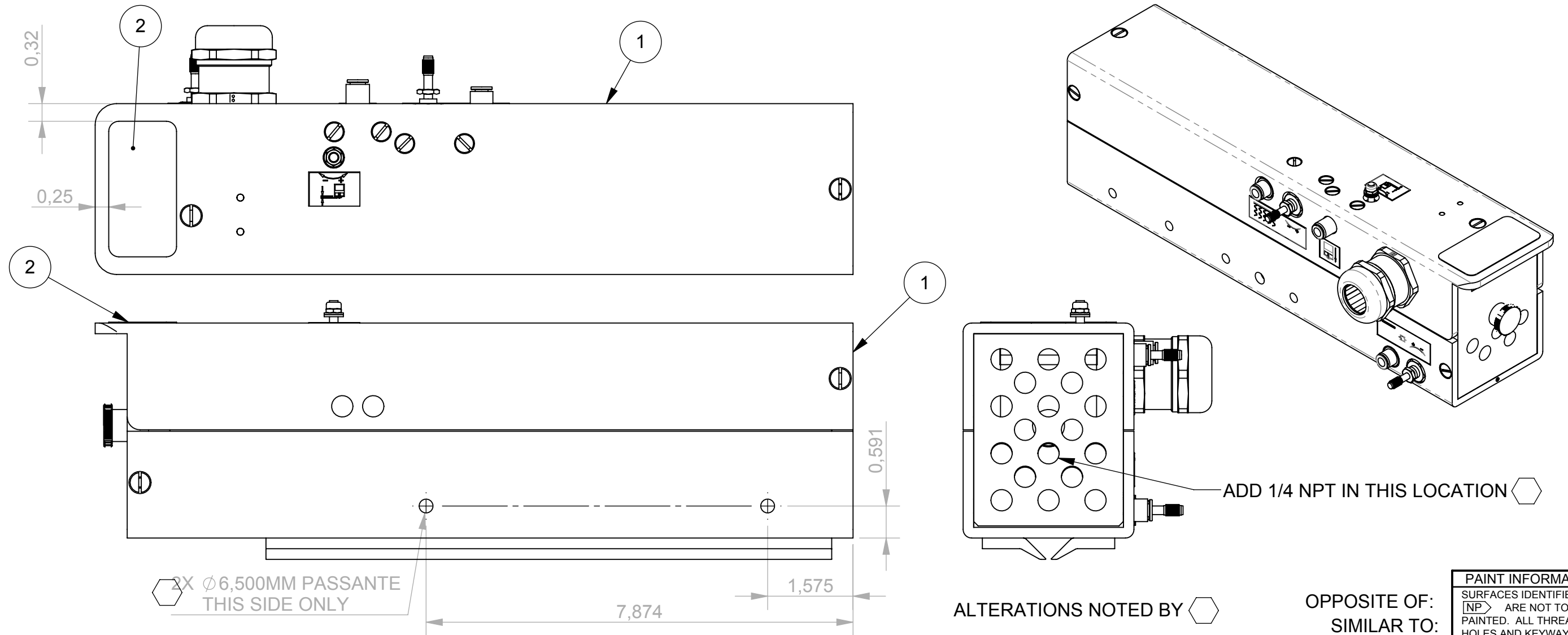

**UNLESS OTHERWISE SPECIFIED, ALL DIMENSIONS ARE IN INCHES.**

INCHES ACROSS CORNERS	TOLERANCES UNLESS OTHERWISE SPECIFIED ARE FOR MACHINED SURFACES ONLY									DECIMAL PLACES	ALL DIMENSIONS IN BRKTS [XX] ARE MILLIMETERS	SURFACE FINISH (MICRO INCHES)	CONCENTRICITY (TIR)	ANGULARITY	MACHINED RADII = .032 MAX NO SHARP CORNERS	RAW MATERIAL			
	PERPENDICULAR	PARALLELISM	FLATNESS	.X	.XX	.XXX	.X	.XX	.XXX							NAME	DRAWN BY	DESIGNER	TOTAL WEIGHT
≤ 25"	.015	.008	.004	.020	.010	.005	.030	.015	.008	±.060 [1.52]	±.030 [0.76]	±.015 [0.38]							
>25 ≤ 50"	.025	.012	.006	.040	.025	.012	.040	.025	.012										
>50 ≤ 75"	.030	.015	.008	.060	.030	.015	.060	.030	.015										
>75 ≤ 100"	.040	.030	.010	.080	.050	.020	.080	.050	.020										
>100"	.050	.040	.015	.090	.070	.025	.090	.070	.025										

01	01	B1	CM_115596 / ADDED 1/4 NPT	13OCT16	RAP	
VER	SHT	LOC	CHANGE NUMBER AND DESCRIPTION	DATE	BY	APVD

<b>THIRD ANGLE PROJECTION</b>		<b>DO NOT SCALE DRAWING</b>		PROPERTY OF THE PAPER CONVERTING MACHINE COMPANY, GREEN BAY, WISCONSIN, USA THIS PRINT IS NOT TO BE COPIED OR REPRODUCED WITHOUT WRITTEN PERMISSION		PART NUMBER <b>30682195</b>	
<b>PAPER CONVERTING MACHINE CO GREEN BAY, WIS, USA</b>				SHT 1 OF 1		SCALE 1:2	SIZE B

DOC NO: 30682195