

RES-420

®

Operating Instructions



Important features

- Microprocessor technology
- LC display (green), 4 lines, 20 characters, (multilingual)
Alternatively:
VF display (blue), 4 lines, 20 characters, (multilingual)
- Automatic zero calibration (AUTOCAL)
- Automatic optimization (AUTOTUNE)
- Automatic configuration of the secondary voltage and current ranges (AUTORANGE, as of software revision 100)
- Automatic phase angle compensation (AUTOCOMP, as of software revision 100)
- Automatic frequency adjustment
- Large current and voltage range
- Booster connection as standard
- Heatsealing band alloy and temperature range selectable
- Alarm function with fault diagnosis

Identical design to and compatible with RES-210, -211, -220, -221

Contents

1	Safety and warning notes	3	10	Controller functions	24
1.1	Use	3	10.1	Indicators and controls	24
1.2	Heatsealing band	3	10.2	Display	25
1.3	Impulse transformer	3	10.3	Navigation in the menus	26
1.4	Current transformer PEX-W2/-W3	3	10.4	Menu structure	28
1.5	Line filter	4	10.5	Two-digit numbering system up to software revision 027	30
1.6	Warranty provisions	4	10.6	Menu steps	31
1.7	Standards / CE marking	4	10.7	Temperature setting (set point selection)	35
2	Application	4	10.8	Temperature indication	35
3	Principle of operation	5	10.9	Automatic zero calibration (AUTOCAL)	35
4	Description of the controller	6	10.10	"START" signal (HEAT)	35
5	Accessories and modifications	7	10.11	Cycle counter	36
5.1	Accessories	7	10.12	Hold mode	36
5.2	Modifications (MODs)	8	10.13	Measuring impulse duration (as of software revision 026)	37
6	Technical data	9	10.14	Automatic phase angle compensation (AUTOCOMP) (as of software revision 100)	37
7	Dimensions/front panel cutout	11	10.15	Locking the "HAND" key (as of software revision 100)	38
8	Installation	12	10.16	Temperature unit Celsius / Fahrenheit (as of software revision 106)	38
8.1	Installation procedure	12	10.17	Disabling the Configuration menu	38
8.2	Installation steps	13	10.18	Setting the display brightness (VF display only)	39
8.3	Power supply	14	10.19	Undervoltage detection	39
8.4	Line filter	15	10.20	Diagnostic interface/visualization software (as of software revision 100)	39
8.5	Current transformer PEX-W3	15	10.21	Booster connection	40
8.6	Wiring diagram (standard)	16	10.22	System monitoring/alarm output	40
8.7	Wiring diagram with booster connection	17	10.23	Error messages	40
9	Startup and operation	18	10.24	Fault areas and causes	44
9.1	Front view of the controller	18	11	Factory settings	46
9.2	Rear view of the controller	18	11.1	Customer settings (as of software revision 100)	47
9.3	Controller configuration	19	12	Maintenance	47
9.4	Heatsealing band	22	13	How to order	48
9.5	Startup procedure	23	14	Index	49

1 Safety and warning notes

This RESISTRON temperature controller is manufactured according to DIN EN 61010-1. In the course of its manufacture it passed through quality assurance, whereby it was subjected to extensive inspections and tests.

It left the factory in perfect condition.

The recommendations and warning notes contained in these operating instructions must be complied with, in order to guarantee safe operation.

The device can be operated within the limits indicated in the "Technical Data" without impairing its operational safety. Installation and maintenance may only be performed by technically trained, skilled persons who are familiar with the associated risks and warranty provisions.

1.1 Use

RESISTRON temperature controllers may only be used for heating and temperature control of heatsealing bands which are expressly suitable for them, and providing the regulations, notes and warnings contained in these instructions are complied with.

 **In case of non-compliance or use contrary to the intended purpose, there is a risk that safety will be impaired or that the heatsealing band, electrical wiring, transformer etc. will overheat. Ensuring such compliance is the personal responsibility of the user.**

1.2 Heatsealing band

A basic prerequisite for reliable and safe operation of the system is the use of suitable heatsealing bands.

 **The resistance of the heatsealing band which is used must have a positive minimum temperature coefficient in order to guarantee trouble-free operation of the RESISTRON temperature controller.**

The temperature coefficient must be specified as follows:

$$TCR \geq 10 \times 10^{-4} \text{K}^{-1}$$

e.g. Alloy-20: TCR = 1100 ppm/K
NOREX: TCR = 3500 ppm/K

The RESISTRON temperature controller must be set and coded according to the temperature coefficient of the heatsealing band.

 **The use of incorrect alloys with a too low temperature coefficient and incorrect coding of the RESISTRON temperature controller lead to uncontrolled heating and ultimately to burn-out of the heatsealing band!**

The heatsealing bands that were originally supplied must be identified by detail specification, part number or some other means that will assure that replacement bands are identical.

1.3 Impulse transformer

A suitable impulse transformer is necessary to ensure that the control loop functions perfectly. This transformer must be designed according to VDE 0570/EN 61558 (isolating transformer with reinforced insulation) and have a one section bobbin. When the impulse transformer is installed, suitable shock protection must be provided in accordance with the national installation regulations for electrical equipment. In addition, water, cleaning solutions and conductive fluids must be prevented from seeping into the transformer.

 **Incorrect installation of the impulse transformer impairs electrical safety.**

1.4 Current transformer PEX-W2/-W3

The current transformer supplied with the RESISTRON temperature controller is an integral part of the control system.

 **Only the original ROPEX PEX-W2 or PEX-W3 current transformer may be used. Other transformers may cause the equipment to malfunction.**

The current transformer may only be operated if it is connected to the RESISTRON temperature controller correctly (see section 9, "Startup and operation"). The relevant safety instructions contained in section 8.3, "Power supply", must be obeyed. External monitoring modules can be used in order to additionally increase

operating safety. They are not included in the scope of supply of the standard control system and are described in a separate document.

1.5 Line filter

The use of an original ROPEX line filter is mandatory in order to comply with the standards and provisions mentioned in section 1.7 "Standards / CE marking" on page 4. This device must be installed and connected according to the instructions contained in section 8.3, "Power supply" as well as the separate documentation enclosed with the line filter.

1.6 Warranty provisions

The statutory provisions for warranties apply for a period of 12 months following the delivery date.

All devices are tested and calibrated in the factory. Devices that have been damaged due to faulty connections, dropping, electrical overloading, natural wear, incorrect or negligent handling, chemical influences or mechanical overloading as well as devices that have been modified, relabeled or otherwise altered by the customer, for example in an attempt to repair them or install additional components, are excluded from the warranty.

Warranty claims must be examined in the factory and approved by ROPEX.

1.7 Standards / CE marking

The controller described here complies with the following standards, provisions and directives:

DIN EN 61010-1 (VDE 0411-1)	Safety provisions for electrical measuring, control and laboratory devices (low voltage directive). Overvoltage category III, pollution severity 2, safety class II.
DIN EN 60204-1	Electrical equipment of machines (machinery directive)
EN 50081-1	EMC interference emissions according to EN 55011, group 1, class B
EN 50082-2	EMC interference immunity: ESDs, RF radiation, bursts, surges.

Compliance with these standards and provisions is only guaranteed if original accessories and/or peripheral components approved by ROPEX are used. If not, then the equipment is operated on the user's own responsibility.

The CE marking on the controller confirms that the device itself complies with the above-mentioned standards.

It does not imply, however, that the overall system also fulfils these standards.

It is the responsibility of the machine manufacturer and of the user to verify the completely installed, wired and operationally ready system in the machine with regard to its conformity with the safety provisions and the EMC directive (see also section 8.3, "Power supply"). If peripheral components (e.g. the transformer or the line filter) from other manufacturers are used, no functional guarantee can be provided by ROPEX.

2 Application

This RESISTRON temperature controller is an integral part of the "series 400", the outstanding feature of which is its microprocessor technology. All RESISTRON temperature controllers are used to control the temperature of heating elements (heatsealing bands, beaded bands, cutting wires, heatsealing blades, solder elements etc.), as required in a variety of heatsealing processes.

The controller is most commonly used for impulse-heatsealing PE and PP films in:

- Vertical and horizontal f/f/s machines
- Pouch, filling and sealing machines
- Film wrapping machines
- Pouch-making machines
- Group packaging machines
- L-sealers

- etc.

The use of RESISTRON temperature controllers results in:

- Repeatable quality of the heatseals under any conditions

- Increased machine capacity

- Extended life of the heatsealing bands and teflon coatings

- Simple operation and control of the sealing process

3 Principle of operation

The resistance of the heatsealing band, which is temperature-sensitive, is monitored 50x per second (60x at 60Hz) by measuring the current and voltage. The temperature calculated with the help of these measurements is displayed and compared with the set point.

The primary voltage of the impulse transformer is adjusted by phase-angle control if the measured values deviate from the set point. The resulting change in the current through the heatsealing band leads to a change in the band temperature and thus also its resistance. This change is measured and evaluated by the RESISTRON temperature controller.

The control loop is closed: ACTUAL temperature = SET temperature. Even minute thermal loads on the heatsealing band are detected and can be corrected quickly and precisely.

The thermoelectric control loop which is formed has a highly dynamic response because purely electrical variables are measured at a high sampling rate. A high secondary current can be controlled with only minimal power loss because power is controlled on the primary side of the transformer. This allows optimum adaptation

to the load and to the required dynamic range despite the exceptionally compact dimensions of the controller.

PLEASE NOTE!

RESISTRON temperature controllers play a significant role in enhancing the performance of modern machines. However, the full benefit can only be obtained from the advanced technology offered by this control system if all the system components, in other words the heatsealing band, the impulse transformer, the wiring, the timing signals and the controller itself, are compatible with one another.

We will be pleased to contribute our many years of experience towards optimizing your heatsealing system.

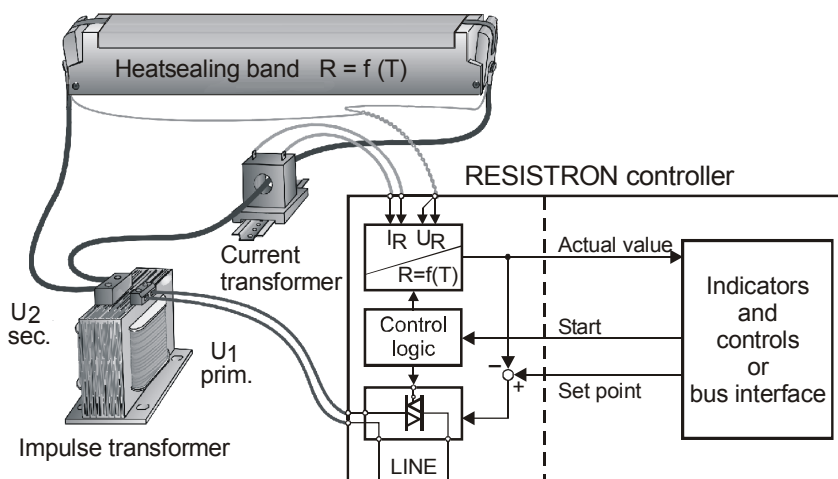

4 Description of the controller

The microprocessor technology endows the RESISTRON temperature controller RES-420 with previously unattainable capabilities:

- Very simple operation thanks to AUTOCAL, the automatic zero calibration function.
- Good dynamic response of the control system thanks to AUTOTUNE, which adapts automatically to the controlled system.
- High precision thanks to further improved control accuracy and linearization of the heatsealing band characteristic.
- High flexibility: The AUTORANGE function (as of software revision 100) covers a secondary voltage range from 0.4V to 120V and a current range from 30A to 500A.
- Automatic adjustment to the line frequency in the range from 47Hz to 63Hz.
- Increased protection against dangerous conditions, such as overheating of the heatsealing band.

The process data is represented on an LC display with 4 lines and 20 characters. Devices with a VF display

are available as an option. Various display languages can be selected.

The real heatsealing band temperature is visualized on the display both as a digital number in °C and in the form of a dynamic bar.

The RESISTRON temperature controller RES-420 also features an integrated fault diagnosis function, which tests both the external system (heatsealing band, wiring etc.) and the internal electronics and outputs a selective error message in case of a fault.

To increase operational safety and interference immunity, all 24VDC logic signals are electrically isolated from the controller and the heating circuit.

The menu in the temperature controller itself can be used to adapt to different heatsealing band alloys (Alloy-20, NOREX etc.) and set the required temperature range (0...300°C, 0...500°C etc.).

The RESISTRON temperature controller RES-420 is designed for installation in a front panel cutout. The compact design and the plug-in connections make this controller easy to install.



5 Accessories and modifications

A wide range of compatible accessories and peripheral devices are available for the RESISTRON temperature controller RES-420. They allow it to be optimally adapted to your specific heatsealing application and to your plant's design and operating philosophy.

5.1 Accessories

The products described below are only a few of the wide range of accessories available for RESISTRON temperature controllers (↪ "Accessories" leaflet).

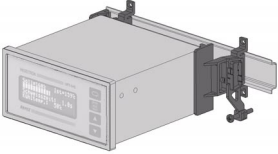
	<p>Line filter LF-xx480 Essential in order to ensure CE conformity. Optimized for the RESISTRON temperature controller.</p>
	<p>Impulse transformer ITR-x Designed according to VDE 0570/EN 61558 with a one-section bobbin. Optimized for impulse operation with RESISTRON temperature controllers. Specified according to the heatsealing application (↪ ROPEX Application Report).</p>
	<p>Communication interface CI-USB-1 Interface for connecting a RESISTRON temperature controller with diagnostic interface (DIAG) to the PC (USB port). Associated PC visualization software for displaying setting and configuration data, and for recording SET and ACTUAL temperatures in real time.</p>
	<p>Booster B-xxx400 External switching amplifier, necessary for high primary currents (continuous current > 5A, pulsed current > 25A).</p>
	<p>Monitoring current transformer For detecting frame short-circuits on the heatsealing band. Used as an alternative to the standard PEX-W2/-W3 current transformer.</p>
	<p>Transparent front cover TFA-1 For increasing the degree of protection on the front of the controller to IP65. Also facilitates applications in the food technology sector (GMP).</p>

	<p>Adapter for top hat rail mounting, HS-Adapter-01 For mounting the RESISTRON temperature controller RES-420 on a top hat rail (DIN TS35). Allows the controller to be installed in the electrical cabinet, for instance, where it is only accessible to authorized persons.</p>
	<p>Lockable door TUER-S/K-1 Transparent door (with lock) for mounting on the bezel of the controller. The display is clearly legible at all times. The keyboard can only be operated, however, by authorized persons in possession of a key.</p>
	<p>Measurement cable UML-1 Twisted measurement cable for the U_R voltage measurement. Trailing cable, halogen and silicone-free.</p>

5.2 Modifications (MODs)

Owing to its universal design, the RESISTRON temperature controller RES-420 is suitable for a very wide range of heatsealing applications.

Modifications (MOD) are available for the RESISTRON temperature controller RES-420 for implementing special applications.

MOD 01

Amplifier for low secondary voltages ($U_R = 0.25 \dots 16 \text{ VAC}$). This modification is necessary, for example, for very short or low-resistance heatsealing bands.

MOD 33

(Software revision 010 or higher)

Important heatsealing process data can be output and logged via a serial RS232 interface (↪ MOD 33" documentation).

⚠ This modification is only recommended for existing applications. The PC visualization software (↪ section 10.20 "Diagnostic interface/ visualization software (as of software revision 100)" on page 39) should be used for all new applications.

6 Technical data

Type of construction	Housing for front panel mounting Dimensions (W x H): 144 x 72mm; depth: 161mm (incl. terminals)
Line voltage	<p><u>All controller manufactured as of December 2005 (as of software revision 100):</u> 115VAC version: 110VAC -15%...120VAC +10% (equivalent to 94...132VAC) 230VAC version: 220VAC -15%...240VAC +10% (equivalent to 187...264VAC) 400VAC version: 380VAC -15%...415VAC +10% (equivalent to 323...456VAC)</p> <p><u>All controllers manufactured as of January 2004 up to November 2005 (up to software revision 027):</u> 115VAC version: 115VAC -15%...120VAC +10% (equivalent to 98...132VAC) 230VAC version: 230VAC -15%...240VAC +10% (equivalent to 196...264VAC) 400VAC version: 400VAC -15%...415VAC +10% (equivalent to 340...456VAC)</p> <p><u>All controllers manufactured up to December 2003:</u> 115VAC, 230VAC or 400VAC, tolerance: +10% / -15%</p> <p>depending on device version (↪ Kap. 13 „How to order“ auf Seite 48)</p>
Line frequency	47...63Hz, automatic adjustment to frequencies in this range
Heatsealing band type and temperature range	<p><u>As of software revision 100:</u> The temperature range and temperature coefficient can be set independently of one another in the Configuration menu: Temperature range: 200°C, 300°C, 400°C or 500°C Temperature coefficient: 400...4000ppm (variable setting range)</p> <p><u>Up to software revision 027:</u> Several different ranges can be selected on the controller in the Configuration menu:</p> <ul style="list-style-type: none"> Temperature coefficient 410ppm, 0...300°C (SW revision 021 or higher) Temperature coefficient 460ppm, 0...300°C (SW revision 019 or higher) Temperature coefficient 510ppm, 0...300°C (SW revision 019 or higher) Temperature coefficient 570ppm, 0...300°C (SW revision 019 or higher) Temperature coefficient 630ppm, 0...300°C (SW revision 019 or higher) Temperature coefficient 700ppm, 0...300°C (SW revision 019 or higher) Temperature coefficient 780ppm (e.g. Alloy L) 0...200°C, 0...300°C, 0...400°C, 0...500°C (SW revision 011 or higher) Temperature coefficient 870ppm, 0...300°C (SW revision 019 or higher) Temperature coefficient 980ppm, 0...300°C (SW revision 019 or higher) Temperature coefficient 1100ppm (e.g. Alloy 20): 0...200°C, 0...300°C, 0...400°C, 0...500°C Temperature coefficient 3500ppm (e.g. NOREX): 0...200°C, 0...300°C
Set point selection	Via the Settings menu in the controller
Digital logic levels Terminals 3, 4	LOW (0V): 0...2VDC HIGH (24VDC): 12...30VDC (max. current input 6mA) Electrically isolated, reverse polarity-protected

START with contact Terminals 2+7	Switching threshold: 3.5VDC, $U_{\max} = 5\text{VDC}$, $I_{\max} = 5\text{mA}$
Alarm relay Terminals 5+6	Contact, potential-free, $U_{\max} = 50\text{V (DC/AC)}$, $I_{\max} = 0.2\text{A}$
Maximum load (primary current of impulse transformer)	$I_{\max} = 5\text{A}$ (duty cycle = 100%) $I_{\max} = 25\text{A}$ (duty cycle = 20%)
Power dissipation	max. 25W
Display	LC display (green), 4 lines, 20 characters, alternatively: VF display (blue), 4 lines, 20 characters
Ambient temperature	+5...+45°C
Degree of protection	Front: IP42 (IP65 with transparent front cover, Art. No. 887000) Back: IP20
Installation	Installed in front panel cutout with (W x H) $138^{(+0.2)} \times 68^{(+0.2)}\text{mm}$ Fastened with clips
Weight	Approx. 1.0kg (incl. connector plug-in parts)
Housing material	Black plastic, type Noryl SE1 GFN2
Connecting cable Type / cross-sections	Rigid or flexible; 0.2...2.5mm ² (AWG 24...12) Plug-in connectors  If ferrules are used, they must be crimped in accordance with DIN 46228 and IEC/EN 60947-1. This is essential for proper electrical contact in the terminals.

7 Dimensions/front panel cutout

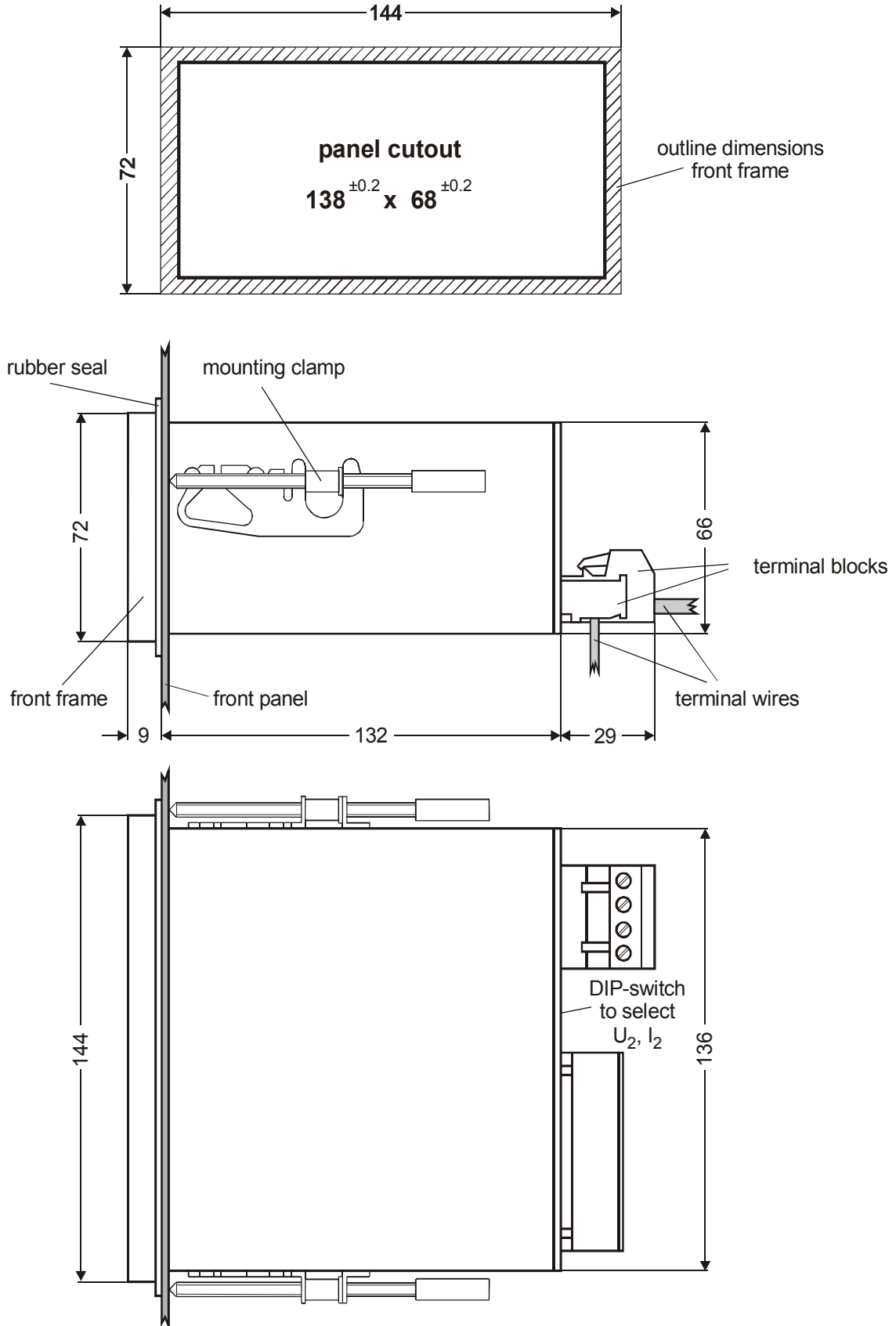

8 Installation

↪ See also Kap. 1 „Safety and warning notes“ auf Seite 3.

⚠ Installation and startup may only be performed by technically trained, skilled persons who are familiar with the associated risks and warranty provisions.

8.1 Installation procedure

Proceed as follows to install the RESISTRON temperature controller RES-420:

1. Switch off the line voltage and verify that all circuits are deenergized.
2. The supply voltage specified on the nameplate of the RESISTRON temperature controller must be identical to the line voltage that is present in the plant or machine. The line frequency is automati-

cally detected by the temperature controller in the range from 47Hz to 63Hz.

3. Install the RESISTRON temperature controller in the front panel cutout. It is fastened by means of two clips which snap onto the side of the controller housing.
4. Wire the system in accordance with the instructions in Kap. 8.3 „Power supply“ auf Seite 14, Kap. 8.6 „Wiring diagram (standard)“ auf Seite 16 and the ROPEX Application Report. The information provided in Kap. 8.2 „Installation steps“ auf Seite 13 must be heeded additionally.

⚠ Check the tightness of all the system connections, including the terminals for the impulse transformer windings.

5. Make sure that the wiring conforms to the relevant national and international installation regulations.

8.2 Installation steps

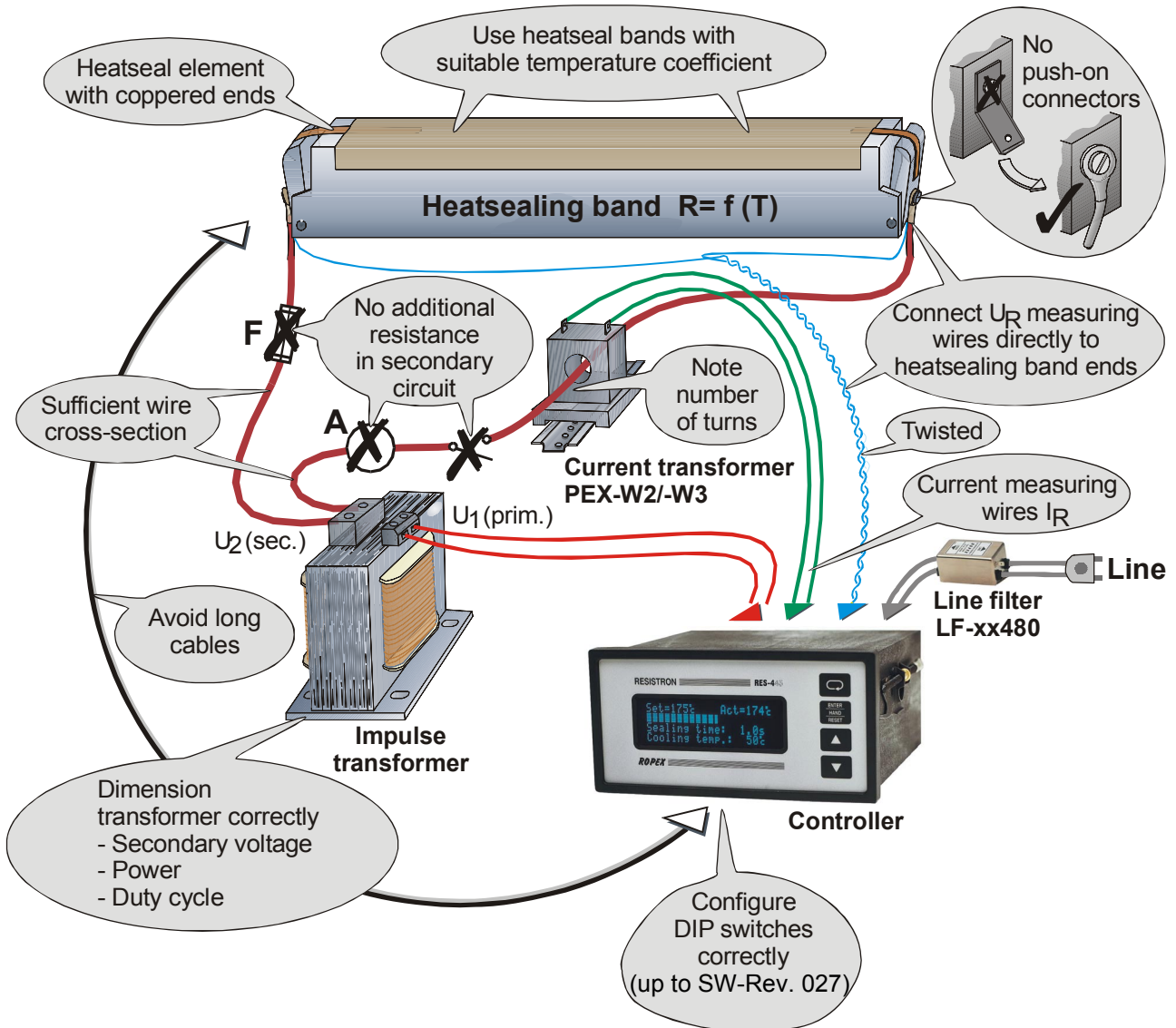

8.3 Power supply

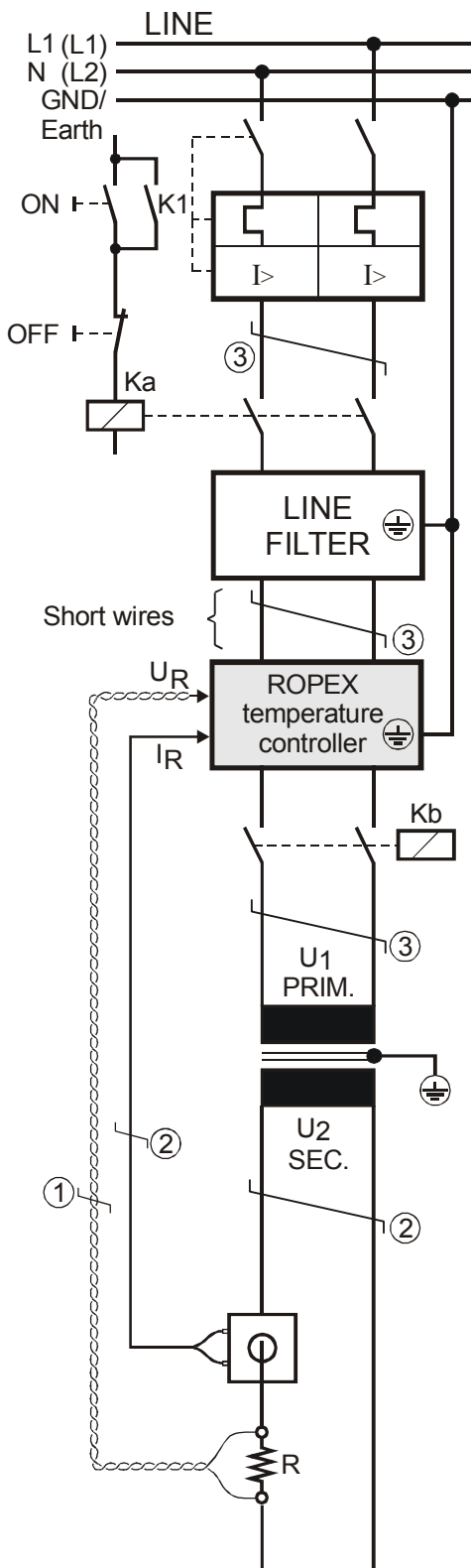

Line

115VAC, 230VAC, 400VAC
50/60Hz

Circuit breaker

Double-pole, C characteristic
(☞ ROPEX Application Report)

⚠ Short-circuit protection only.
RESISTRON temperature controller not protected.

Relay Ka

For "HEAT ON - OFF" function (all-pole) or "EMERGENCY STOP".

Line filter

The filter type and size must be determined according to the load, the transformer and the machine wiring (☞ ROPEX Application Report).

⚠ Do not run the filter supply wires (line side) parallel to the filter output wires (load side).

RESISTRON temperature controller belonging to the 4xx Series.

Relay Kb

Load break (all-pole), e.g. in combination with the alarm output of the temperature controller.

⚠ When using a series resistor RV-....-1 the relay Kb shall be installed.

Impulse Transformer

Designed according to VDE 0570/EN 61558 (isolating transformer with reinforced insulation). Connect core to ground.

⚠ Use transformers with a one section bobbin. The power, duty cycle and voltage values must be determined individually according to the application (☞ ROPEX Application Report and "Accessories" leaflet for impulse transformers).

Wiring

The wire cross-sections depend on the application (☞ ROPEX Application Report).

Guide values:

Primary circuit: min. 1.5mm², max. 2.5mm²

Secondary circuit: min. 4.0mm², max. 25mm²

- ① These wires must always be twisted (>20/m)
- ② These wires must be twisted (>20/m) if several control loops are laid together ("crosstalk").
- ③ Twisting (>20/m) is recommended to improve EMC.

8.4 Line filter

To comply with EMC directives – corresponding to EN 50081-1 and EN 50082-2 – RESISTRON control loops must be operated with line filters. These filters damp the reaction of the phase-angle control on the line and protect the controller against line disturbances.

⚠ The use of a suitable line filter is part of the standards conformity and a prerequisite of the CE mark.

installed and wired correctly, they guarantee compliance with the EMC limit values. You can find the exact specification of the line filter in the ROPEX Application Report calculated for your particular heatsealing application. For more technical information: ↪ "Line filter" documentation.

⚠ It is permissible to supply several RESISTRON control loops with a single line filter, providing the total current does not exceed the maximum current of the filter.

ROPEX line filters are specially optimized for use in RESISTRON control loops. Providing that they are

The wiring instructions contained in section 8.3 "Power supply" on page 14 must be observed.

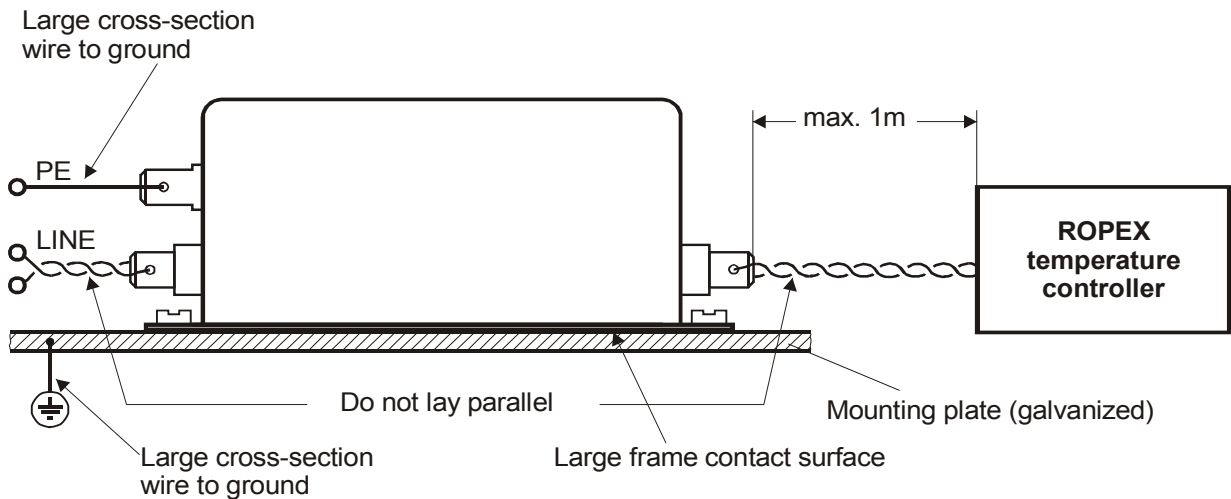

8.5 Current transformer PEX-W3

The PEX-W3 current transformer supplied with the RESISTRON temperature controller is an integral part

of the control system. The current transformer may only be operated if it is connected to the temperature controller correctly (↪ section 8.3 "Power supply" on page 14).

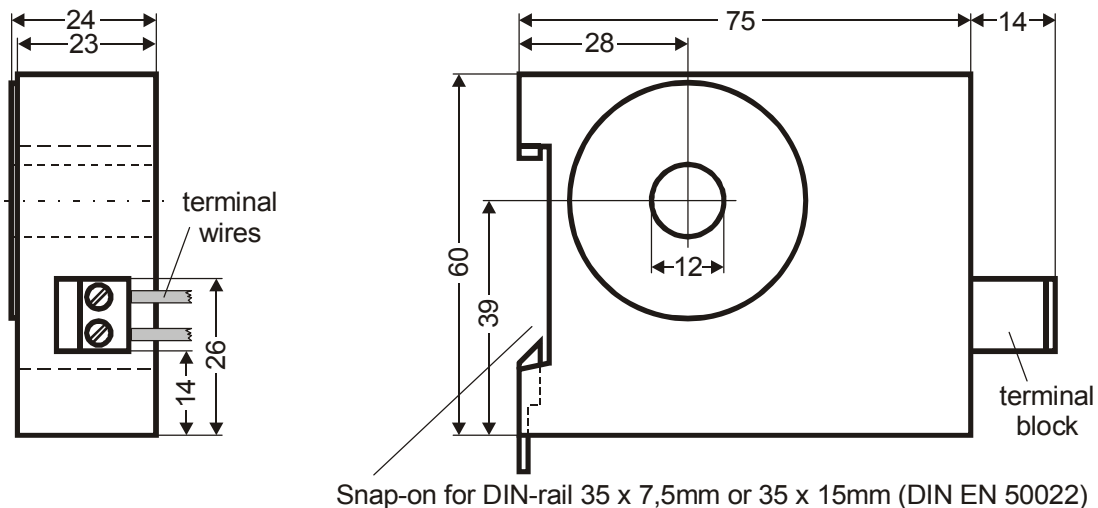

8.6 Wiring diagram (standard)

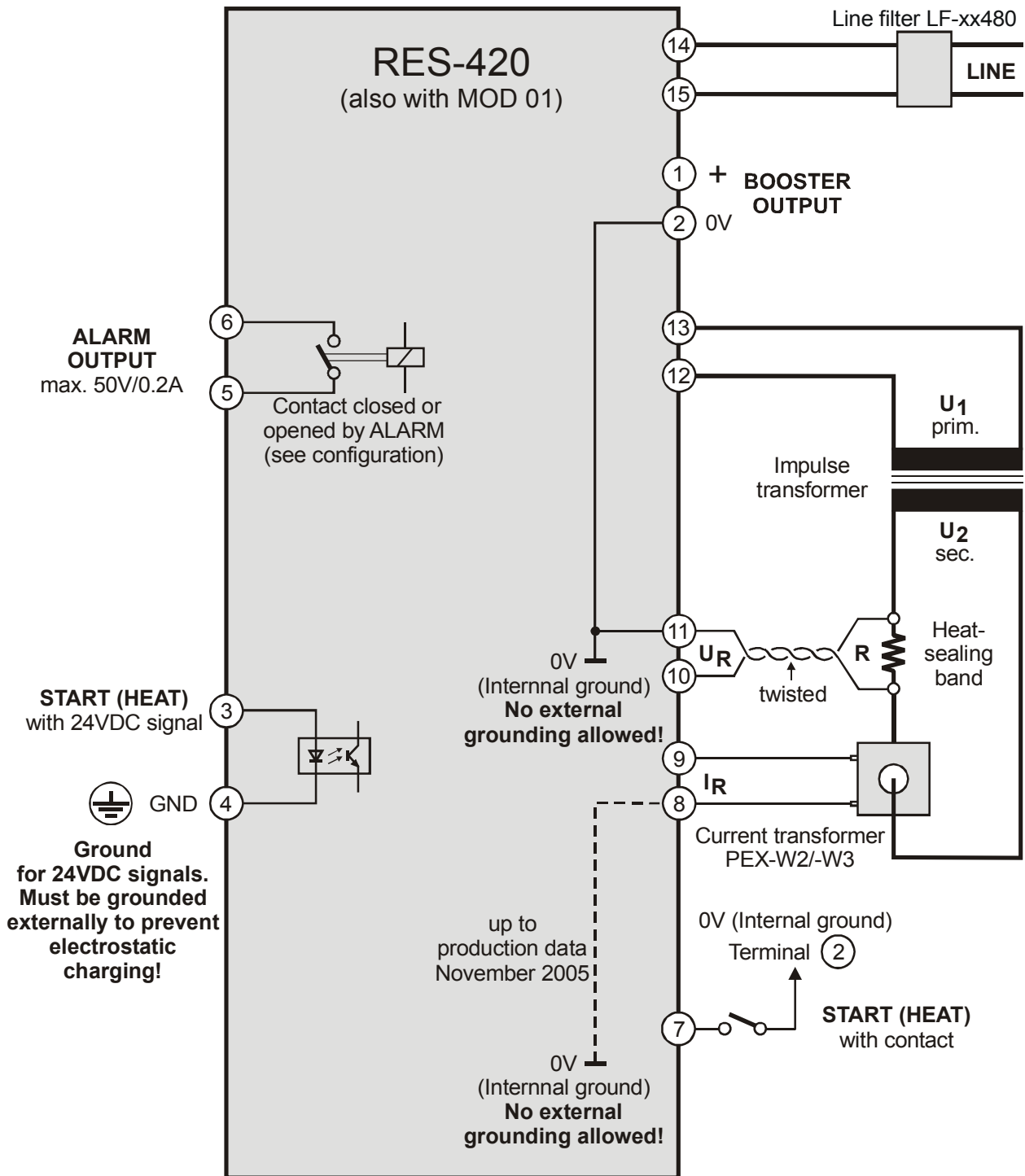

8.7 Wiring diagram with booster connection

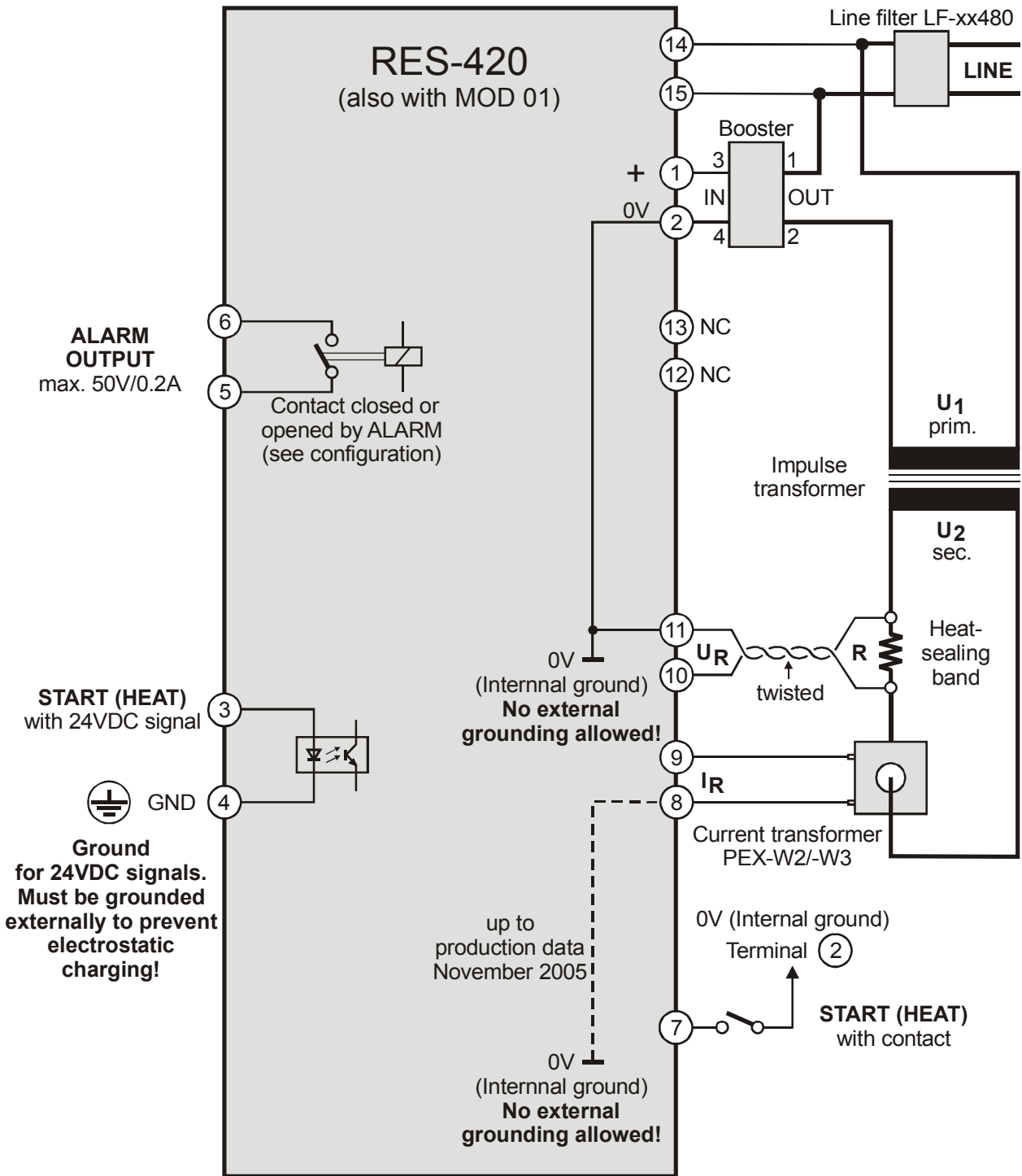

9 Startup and operation

9.1 Front view of the controller

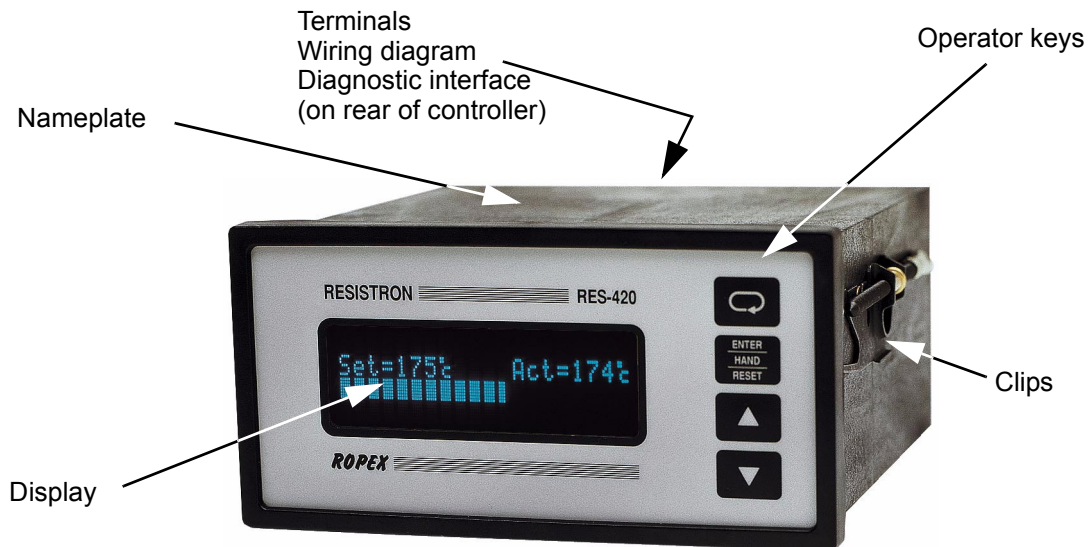

9.2 Rear view of the controller

As of software revision 100:

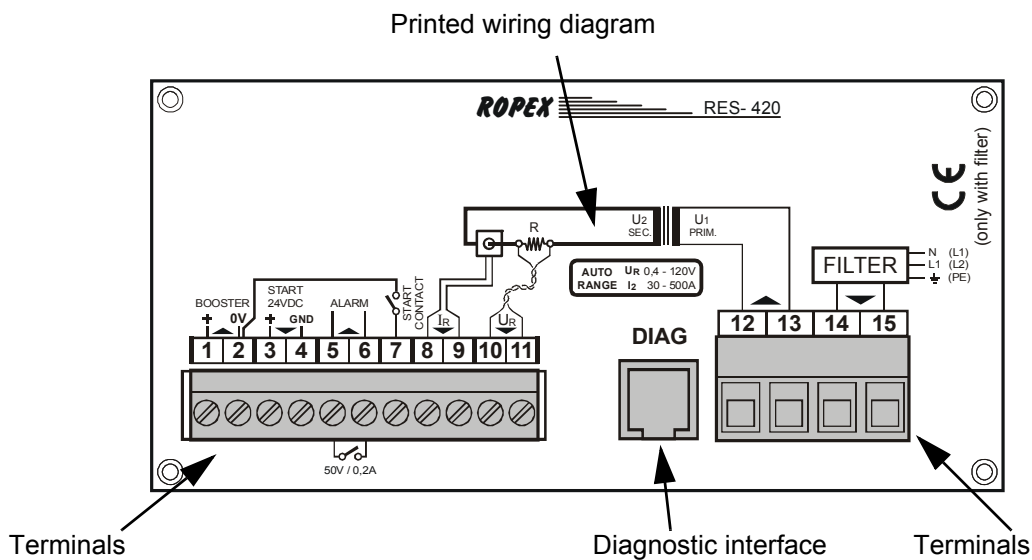

Up to software revision 027:

Printed wiring diagram

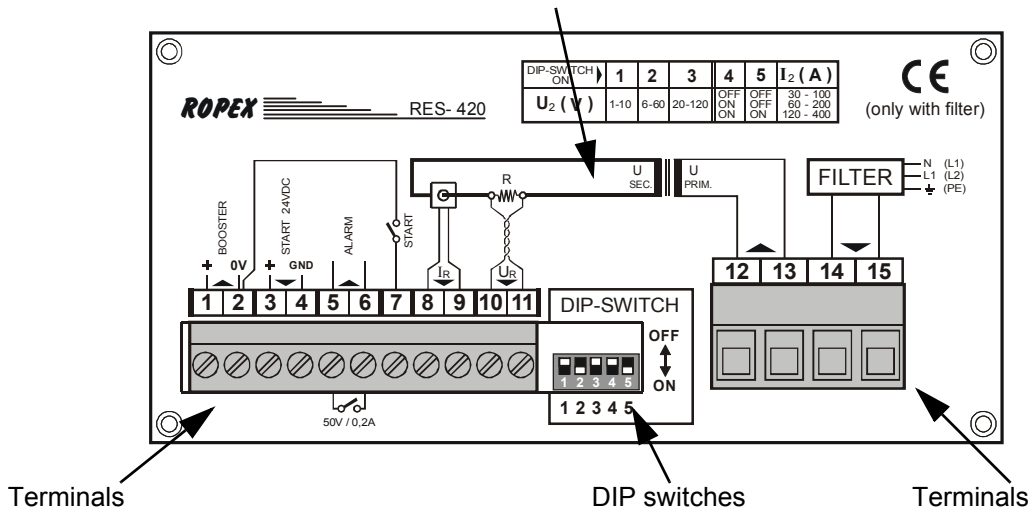

9.3 Controller configuration

The possible controller configurations are explained in the following sections. Proceed as described in Kap. 9.5.1 „Initial startup“ auf Seite 23 to start up the controller for the first time.

9.3.1 Configuration of the DIP switches for secondary voltage and current

⚠ The controller must be switched off in order to configure the DIP switches.

**Automatic configuration (AUTORANGE)
(as of software revision 100)**

The secondary voltage and current ranges are automatically configured by the automatic calibration func-

tion (AUTOCAL). The voltage is configured in the range from 0.4VAC to 120VAC and the current in the range from 30A to 500A. If the voltage and/or the current is outside the permissible range, a detailed error message appears on the controller (↪ s. section 10.24 "Fault areas and causes" on page 44).

**Configuration with coding switches
(up to software revision 027)**

Set the DIP switches for matching the secondary voltage U_2 and the secondary current I_2 to the correct position for **your** application.

⚠ You can find the exact configuration of the DIP switches in the ROPEX Application Report calculated for your particular application.

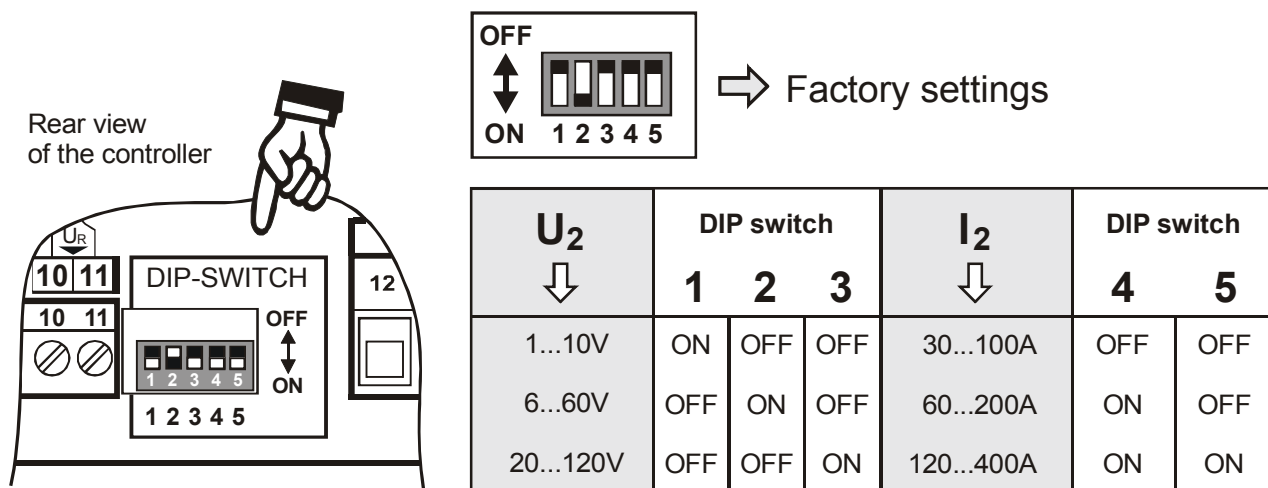

If the secondary current I_2 is less than 30A, the PEX-W2/W3 current transformer must have two turns (↪ ROPEX Application Report).

! If the controller settings are unknown when it is started up for the first time, the factory settings must be restored in order to prevent malfunctions.



9.3.2 Setting the language

The menu language can be changed on the controller without interrupting operation. It is set with step 20 in the Configuration menu:

The following settings are possible:

English, German, Italian

Software revision 015 or higher also:

French, Spanish, Dutch, Danish, Finnish, Swedish, Greek, Turkish.

Software revision 024 or higher also: Portuguese.

! The language which is selected in this menu remains set even if the factory settings are restored (step 202 [21] in the Configuration menu).

! As of software revision 103, the language setting with step 202 can still be changed even if the Configuration menu is disabled.

9.3.3 Restoring the factory settings

The internal controller settings can be reset to the factory settings with step 202 [21] in the Configuration menu. Only the language setting (step 201 [20] in the Configuration menu) remains unchanged.

Please refer to section 11 "Factory settings" on page 46 for more information about the factory settings.

9.3.4 Configuration of the alloy and the temperature range (up to software revision 027)

These parameters are set with step 22 in the Configuration menu:

Several different ranges can be selected:

1. **Temperature coefficient 410 ppm, 0...300°C** (software revision 021 or higher)
2. **Temperature coefficient 460 ppm, 0...300°C** (software revision 019 or higher)
3. **Temperature coefficient 510 ppm, 0...300°C** (software revision 019 or higher)
4. **Temperature coefficient 570 ppm, 0...300°C** (software revision 019 or higher)
5. **Temperature coefficient 630 ppm, 0...300°C** (software revision 019 or higher)
6. **Temperature coefficient 700 ppm, 0...300°C** (software revision 019 or higher)
7. **Temperature coefficient 780 ppm, 0...200°C** (e.g. Alloy L, software revision 011 or higher)
8. **Temperature coefficient 780 ppm, 0...300°C** (e.g. Alloy L, software revision 011 or higher)
9. **Temperature coefficient 780 ppm, 0...400°C** (e.g. Alloy L, software revision 011 or higher)
10. **Temperature coefficient 780 ppm, 0...500°C** (e.g. Alloy L, software revision 011 or higher)
11. **Temperature coefficient 870 ppm, 0...300°C** (software revision 019 or higher)
12. **Temperature coefficient 980 ppm, 0...300°C**

(software revision 019 or higher)

13. **Temperature coefficient 1100 ppm, 0...200°C**
(e.g. Alloy-20)
14. **Temperature coefficient 1100 ppm, 0...300°C**
(Factory settings)
(e.g. Alloy-20)
15. **Temperature coefficient 1100 ppm, 0...400°C**
(e.g. Alloy-20)
16. **Temperature coefficient 1100 ppm, 0...500°C**
(e.g. Alloy-20)
17. **Temperature coefficient 3500 ppm, 0...200°C**
(e.g. NOREX)
18. **Temperature coefficient 3500 ppm, 0...300°C**
(e.g. NOREX)

9.3.5 Configuration of the alloy (Temperature coefficient) (as of software revision 100)

The heatsealing band alloy (and the temperature coefficient respectively) can be set with steps 203 and 204 in the Configuration menu.

In step 203 predefined values for the alloy (and the temperature coefficient respectively) are available:

1. **Temperature coefficient 780 ppm**
(e.g. Alloy-L)
2. **Temperature coefficient 1100 ppm**
(Factory setting)
(e.g. Alloy-20)
3. **Temperature coefficient 1400 ppm**
(e.g. ROPEX CIRUS system)
4. **Temperature coefficient 1700 ppm**
(e.g. ROPEX CIRUS system)
5. **Temperature coefficient 3500 ppm**
(e.g. NOREX)
6. **Temperature coefficient „variable“**
Further settings in step 204.

In step 204 the temperature coefficient can be set in a range of 400...4000 ppm individually for the used heatsealing band then.

 **Step 204 in the Configuration menu is available when step 203 is set to "variable" only.**

9.3.6 Configuration of the temperature range (as of software revision 100)

The temperature range can be set with steps 205 in the Configuration menu.

The setting can be 200°C, 300°C (Factory setting), 400°C or 500°C.

9.3.7 Temperature diagnosis (as of software revision 100)

The temperature diagnosis function can be activated by means of step 217 in the Configuration menu. The RES-420 then checks whether the ACTUAL temperature is inside a specifiable tolerance band ("OK" window) on either side of the SET temperature. The lower ($\Delta\vartheta_{lower}$) and upper ($\Delta\vartheta_{upper}$) limits of the tolerance band can be changed independently of one another by means of steps 207 [24] + 208 [25] (factory setting: -10K or +10K).

If the ACTUAL temperature is inside the specified tolerance band when the "START" signal is activated, the temperature diagnosis is also activated. If the ACTUAL temperature leaves the tolerance band, the corresponding error code (307, 308) is indicated and the fault output is switched (see section 10.24 "Fault areas and causes" on page 44).

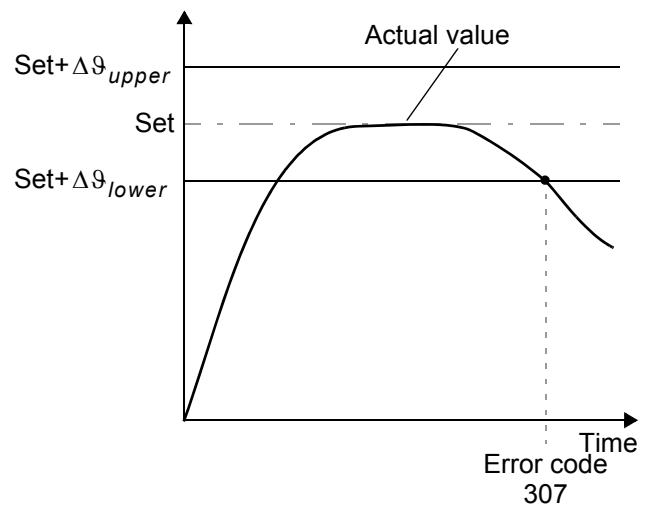

If the temperature diagnosis is not activated by the time the "START" signal is deactivated (i.e. if the ACTUAL temperature does not exceed the upper or lower tolerance band limit), the corresponding error code (309, 310) is indicated and the fault relay is switched. If the temperature diagnosis function is activated, an additional delay time of 0 to 9.9s can be parameterized for the temperature timeout with step 218 in the Configuration menu. The first time the lower tolerance band limit is exceeded, the temperature diagnosis is not activated until the parameterized delay time has elapsed. The temperature diagnosis function can thus be explicitly deactivated, e.g. if the temperature drops temporarily owing to the closure of the sealing jaws.

9.3.8 Heatup timeout (as of software revision 100)

The heatup timeout can be parameterized with step 219 in the Configuration menu ("0" = OFF). This timeout starts when the START signal is activated. The RES-420 then monitors the time required for the ACTUAL temperature to reach 95% of the SET temperature. If this time is longer than the parameterized time, the corresponding error code (304) is indicated and the fault relay is switched (↪ section 10.24 "Fault areas and causes" on page 44).

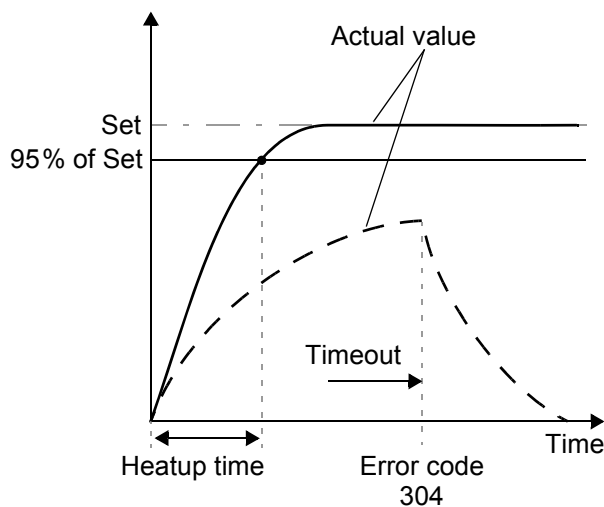

9.3.9 Configuration of the alarm relay

The alarm relay is set with step 215 [25] in the Configuration menu.

There are two possible settings:

1. **"Normal"**
Alarm relay contact closed by a fault
2. **"Inverse"**
Alarm relay contact opened by a fault

9.4 Heatsealing band

9.4.1 General

The heatsealing band is a key component in the control loop, since it is both a heating element and a sensor. The geometry of the heatsealing band is too complex to be discussed at length here. We shall therefore only refer to a few of the most important physical and electrical properties:

The measuring principle applied for this system necessitates a heatsealing band alloy with a suitable temperature coefficient TCR, i.e. one whose resistance increases as the temperature rises.

Too low a TCR leads to oscillation or uncontrolled heating.

When heatsealing bands with a higher TCR are used, the controller must be calibrated for this.

The first time the heatsealing band is heated to approximately 200...250°C, the standard alloy undergoes a once-only resistance change (burn-in effect). The cold resistance of the heatsealing band is reduced by approximately 2...3%. However, this at first glance slight resistance change results in a zero point error of 20...30°C. The zero point must therefore be corrected after a few heating cycles (↪ chap. 9.4.2 „Burning in the heatsealing band“, page 22).

One very important design feature is the copper or silver-plating of the heatsealing band ends. Cold ends allow the temperature to be controlled accurately and increase the life of the teflon coating and the heatsealing band.

⚠ An overheated or burned-out heatsealing band must no longer be used because the TCR has been altered irreversibly.

9.4.2 Burning in the heatsealing band

If a new heatsealing band has been used, the zero point is first of all calibrated while the band is still cold by activating the "AUTOCAL" function on the controller. When the "AUTOCAL" function has finished, the controller outputs the preselected calibration temperature (default value: 20°C). Adjust the set point to approximately 250°C and press the "HAND" key (display in home position) to heat for approximately 1 second. After recooling, the controller usually indicates a value less than 20°C. Repeat the "AUTOCAL" function. The heatsealing band has now been burned in and the change in the alloy properties stabilized.

The burn-in effect described here does not occur if the heatsealing band has already been thermally pre-treated by the manufacturer.

9.4.3 Replacing the heatsealing band

All power supply leads must be disconnected from the RESISTRON temperature controller in order to replace the heatsealing band.

⚠ The heatsealing band must be replaced in accordance with the instructions provided by the manufacturer.

Each time the heatsealing band is replaced, the zero point must be calibrated with the AUTOCAL function while the band is still cold, in order to compensate pro-

duction-related resistance tolerances. The burn-in procedure described above must be performed for all new heatsealing bands.

9.5 Startup procedure

Please also refer to Kap. 1 „Safety and warning notes“ auf Seite 3 and Kap. 2 „Application“ auf Seite 4.

⚠ Installation and startup may only be performed by technically trained, skilled persons who are familiar with the associated risks and warranty provisions.

9.5.1 Initial startup

Prerequisites: The controller must be correctly installed and connected (↳ Kap. 8 „Installation“ auf Seite 12). The possible settings are described in detail in chap. 9.3 „Controller configuration“, page 19 and chap. 10 „Controller functions“, page 24. The essential controller configurations are described below:

1. Switch off the line voltage and verify that all circuits are deenergized.
2. The supply voltage specified on the nameplate of the controller must be identical to the line voltage that is present in the plant or machine. The line frequency is automatically detected by the temperature controller in the range from 47 to 63Hz.
3. In case of controllers up to software revision 027, the setting of the DIP switches on the controller are indicated in the ROPEX Application report and depend on the heatsealing band (section 9.3 "Controller configuration" on page 19).
4. Make sure that a START signal is not present.
5. Switch on the line voltage.
6. A power-up message appears on the display for approximately 2 seconds when the controller is switched on to indicate that it has been started up correctly.

7. One of the following states then appears:

DISPLAY	ACTION
Main menu	Go to 8
Error message with error codes 104...106, 111...113, 211	Go to 8
Error message with error codes 101...103, 107, 108, 201...203, 801, 9xx	Fault diagnosis (↳ 10.24)

8. Set the controller configuration as described in Kap. 9.3 „Controller configuration“ auf Seite 19. The following settings are always required:

Setting	Step in Configuration menu
Language	201 [20]
Restore factory settings	202 [21]
Temperature range and heatsealing band alloy	203, 204, 205 [22]

9. Activate the AUTOCAL function while the heatsealing band is still cold (with step 7 in the Settings menu). The progress of the calibration process is indicated by a counter on the display (approx. 10...15s).
When the zero point has been calibrated, the display is reset to the home position and 20°C is indicated as the actual value.
If the zero has not been calibrated successfully, an error message indicates error codes 104...106, 211. In this case the controller configuration is incorrect (↳ Kap. 9.3 „Controller configuration“ auf Seite 19 and ROPEX Application Report). Repeat the zero point calibration after the controller has been configured correctly.
10. When the zero point has been calibrated successfully, the main menu appears on the display again. Then specify a defined temperature (heatsealing temperature) with step 1 in the Settings menu and activate the "START" signal (HEAT). Alternatively, a heatsealing process can be started by pressing the "HAND" key (display in home position). The indication of the ACTUAL temperature on the display (digital value and dynamic bar) permits the heating and control process to be monitored.
The controller is functioning correctly if the temperature indicated on the display has a continuous

curve, in other words it must not jump abruptly, fluctuate or deviate temporarily in the wrong direction. This kind of behavior would indicate that the U_R measuring wire has been laid incorrectly. If an error code is displayed, please proceed as described in section 10.24 "Fault areas and causes" on page 44.

11. Burn in the heatsealing band (↪ Kap. 9.4 „Heatsealing band“ auf Seite 22) and repeat the AUTOCAL function.

The controller is now ready

9.5.2 Restart after replacing the heatsealing band

To replace the heatsealing band, proceed as described in Kap. 9.4 „Heatsealing band“ auf Seite 22.

Always use a heatsealing band with the correct alloy, dimensions and copper-plating in order to avoid malfunctions and overheating.

Continue with section 9.5.1, steps 9 and 10.

10 Controller functions

See also Kap. 8.6 „Wiring diagram (standard)“ auf Seite 16.

10.1 Indicators and controls

"MENU" key for advancing to next menu step or switching menu
 < 1 sec. Press: Next menu step
 1-2 sec. Press: Return to previous position (as of SW-Revision 100);
 > 2 sec. Press (Hold): Return to home position

"ENTER" key
 ENTER function: Save values
 HAND function: Manual mode
 RESET function: Reset after alarm

"UP" and "DOWN" keys for setting values
 Press (< 2 sec.): Slow change
 Hold (> 2 sec.): Fast change

LC display, 4 lines, multilingual
 optional:
 VF display, 4 lines, multilingual

RESISTRON RES-4

Soll=175% Ist=174%

ROPEX

10.2 Display

This message also includes details of the software version.

10.2.1 Power-up message

A power-up message appears on the display for approximately 2 seconds when the controller is switched on.



Company name (optional: customer-specific)

Software ID number

Controller type (RES-420)

10.2.2 Display in home position

If no settings are entered on the controller and no error message are present, the display is in the home position, in other words it indicates the SET temperature as a digital value and the ACTUAL temperature as a digital value and a dynamic bar.

tion, in other words it indicates the SET temperature as a digital value and the ACTUAL temperature as a digital value and a dynamic bar.

Specified heatsealing temperature (SET temperature)

Measured ACTUAL temperature

ACTUAL temperature as a dynamic bar

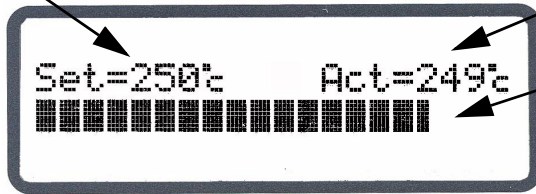

10.2.3 Settings/Configuration menus

The required parameters are set on two menu levels: the Settings (control) menu and the Configuration menu (↳ Kap. 10.4 „Menu structure“ auf Seite 28).

Menu level: Settings or Configuration menu (Configuration menu shown here)

Position in menu (menu step)

Menu contents (max. 3 lines)

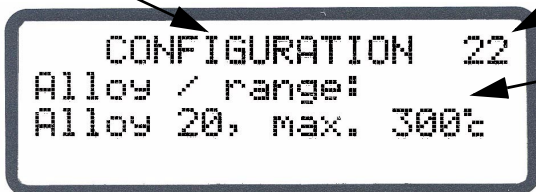

10.2.4 Error messages

The fault diagnosis function of the controller is always active. If a fault is detected, it is indicated on the display

immediately in the form of an error message (→ Kap. 10.22 „System monitoring/alarm output“ auf Seite 40).

Alarm indication

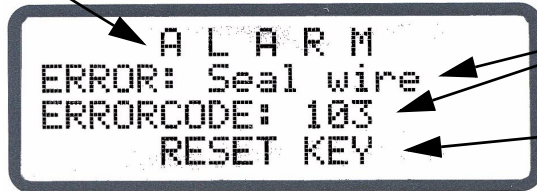

Fault description and error code

Prompt to press "RESET" key

10.3 Navigation in the menus

10.3.1 Navigation in menus without a fault

A "MENU" key is provided for navigating through the various menu steps and levels. By pressing this key briefly (<1s) at any time, you can jump to the next menu step. As of software revision 100, you can also jump to the previous menu step by pressing the "MENU" key for 1-2s. By pressing the key for longer (>2s), you can return to the home position from anywhere in the menu

structure, providing a controller alarm is not active. In this case, the Alarm menu is opened instead.

If the display is in the home position or an alarm is indicated and you press the "MENU" key for longer than 2s, you are taken directly to the configuration level (starting at step 201 [20]).

In addition, you always return to the home position if you do not press any keys for a period of 30s. There is no automatic return after 30s from "AUTOCAL" or "Alarm".

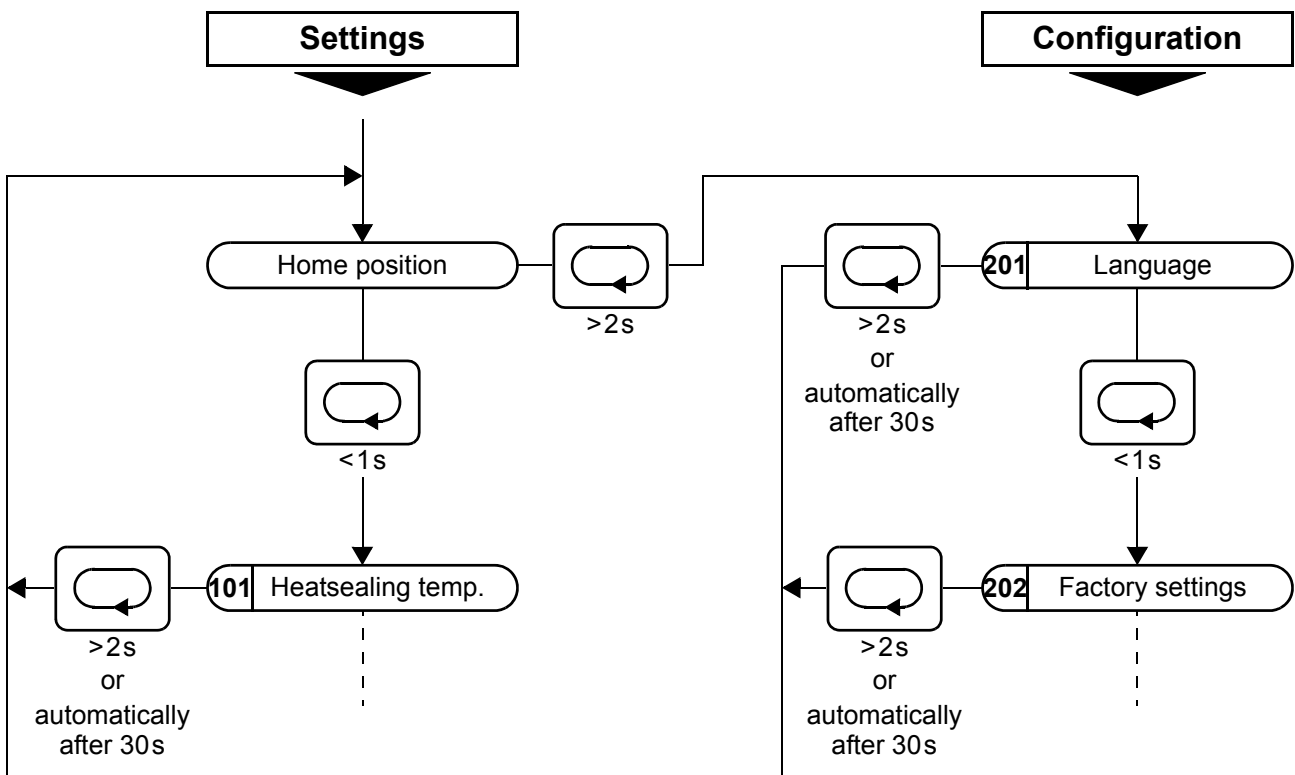

10.3.2 Navigation in menus with a fault

If an alarm is signaled, the controller switches to the Alarm menu. Some faults can be acknowledged by pressing the "RESET" key (↵ Kap. 10.22 „System monitoring/alarm output“ auf Seite 40). In this case, the controller switches back to the home position. If the fault can be rectified by executing the AUTOCAL function, you can select the "AUTOCAL" menu step directly by briefly pressing the "MENU" key (<2s). You

can then activate the "AUTOCAL" function by pressing the "ENTER" key (↵ section 10.9 "Automatic zero calibration (AUTOCAL)" on page 35). If you press the "MENU" key for longer than 2s in the Alarm menu, you are taken directly to the configuration level (starting at step 201 [20]). You can return from the Configuration menu to the Alarm menu either by pressing the "MENU" key for longer than 2s or by not pressing any keys for 30s.

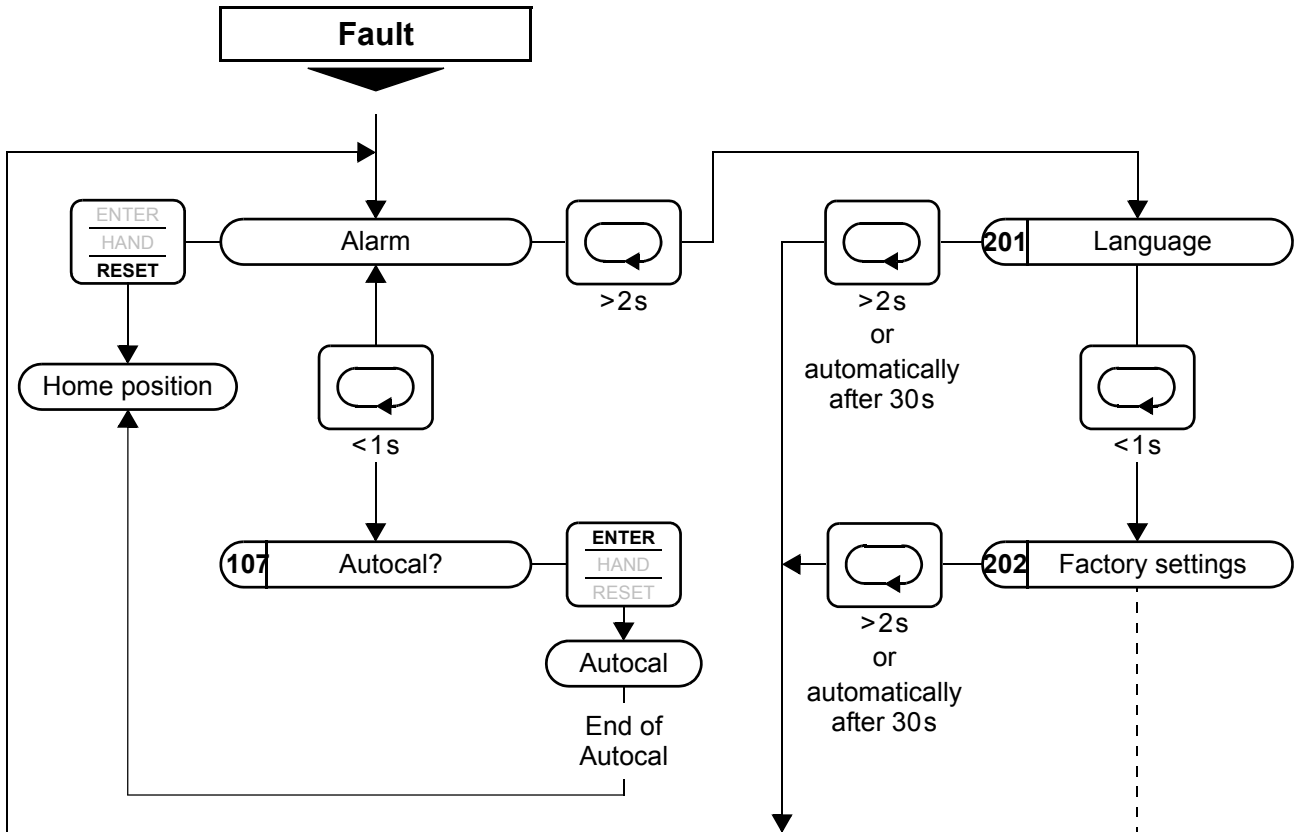

10.4 Menu structure

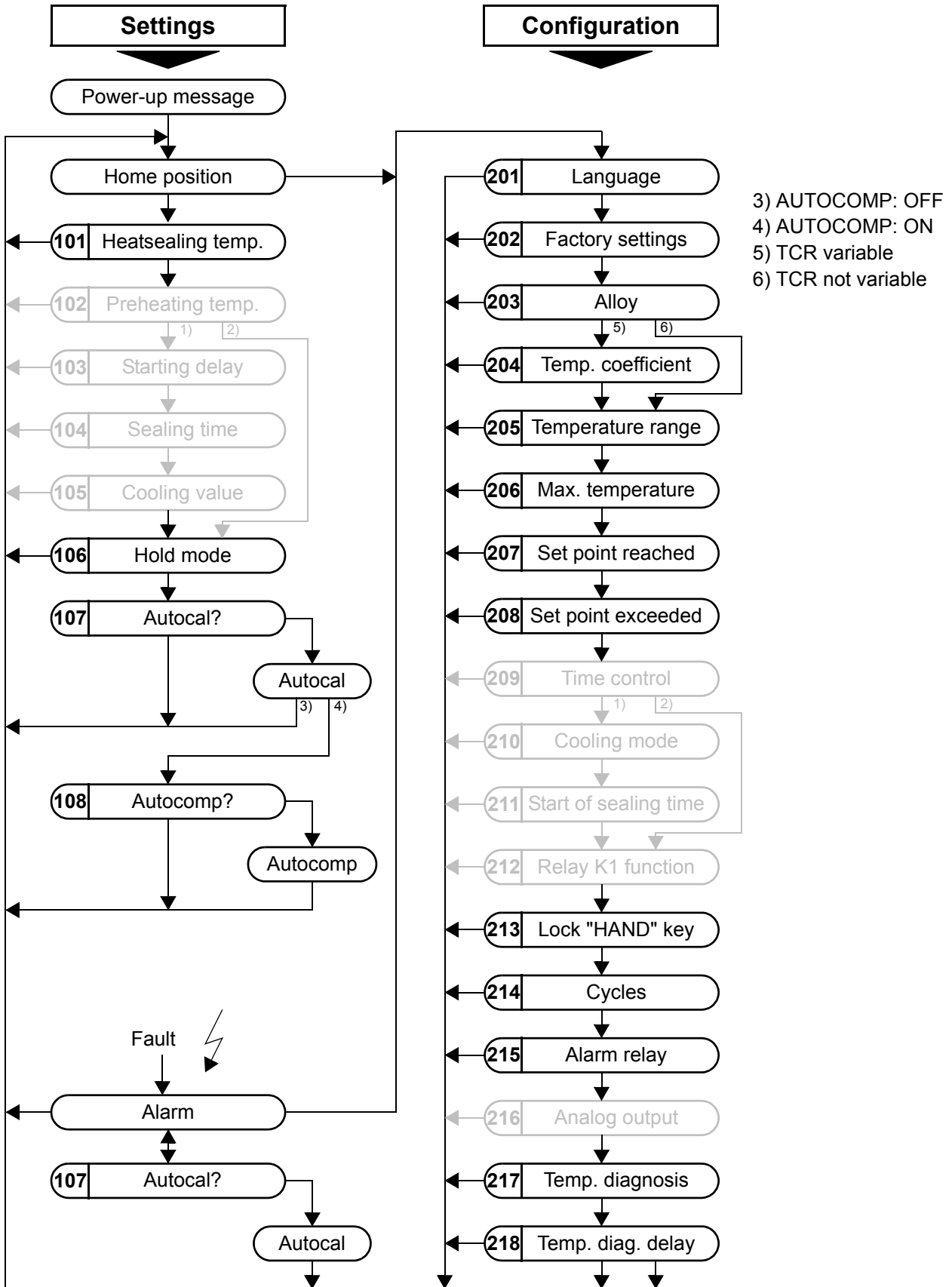

Continued on next page

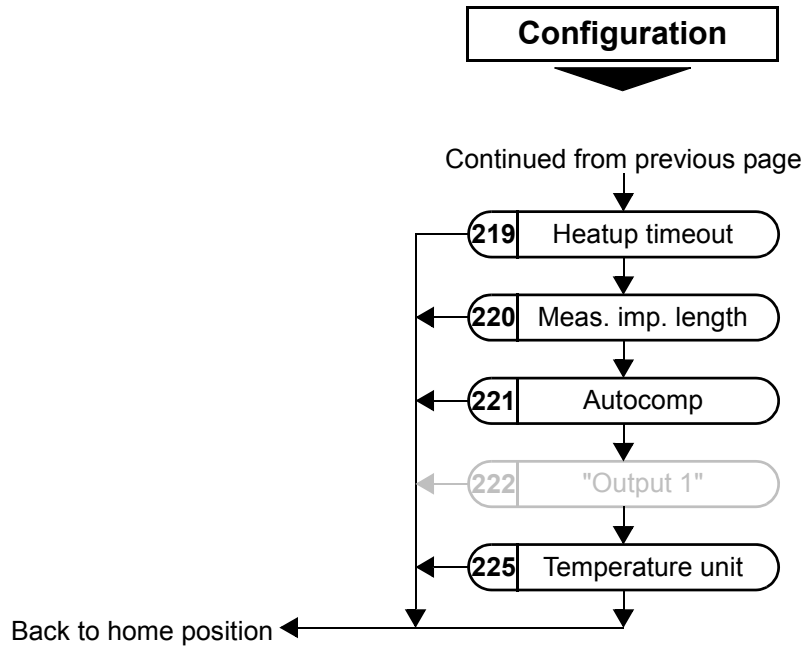

10.5 Two-digit numbering system up to software revision 027

A system of one and two-digit numbers was used for the Settings and Configuration menus up to software

revision 027. Three-digit numbers were introduced in software revision 100 to improve the clarity of the menu structure.

The table below compares the two numbering systems:

Menu	Menu steps	Numbering up to software revision 027	Numbering as of software revision 100
Settings menu	Heatsealing temperature	1	101
	Hold mode	2	106
	AUTOCAL	3	107
Configuration menu	Language	20	201
	Factory settings	21	202
	Alloy / TCR	22	203, 204
	Maximim temperature	23	206
	Cycles	24	214
	Alarm relay	25	215
	Measuring pulse length	26	220



 All number sor menu steps not listed above are only available as of software revision 100 and are described in chap. 9 „Startup and operation“, page 18 (and section 10.4 "Menu structure" on page 28 respectively).

 The new, three-digit menu step numbers are described first in all relevant sections of this document. The older, two-digit numbers are indicated afterwards in square brackets (e.g. step 201 [20]).

10.6 Menu steps

No.	Name	Description	Setting range
	Home position	The specified set value and the current actual value are displayed in digital form. The actual value is also represented as a dynamic bar. If time control (step 209 [26]) is active, the heatsealing time and the cooling value are also displayed. The heatsealing band can be heated manually (to the specified heatsealing temperature) by pressing the "HAND" key.	
101 [1]	Heatsealing temperature	The required heatsealing temperature (set point) can be set with the "UP" and "DOWN" keys. The maximum selectable set point can be limited with step 203 [22] (alloy/range) and step 204 [23] (max. temperature). The set point is indicated in the home position.	Depends on setting of step 205 [22]: 0, 40 °C...maximum temperature (step 206 [23])
106 [2]	Hold mode	If the "Hold" function is activated, the last measured value at the end of the heating phase is stored and displayed. The "ACT" (actual value) information in the home position is replaced by "Hold". This procedure is repeated for every cycle and the displayed value is updated. The word "Hold" is invisible for 100ms before the value is updated. If you select the "2 second hold" function, the display changes back from hold mode to the actual value in real time after 2 seconds. The hold function is then activated again for 2 seconds at the end of the next cycle.	ON OFF 2 s
107 [3]	Autocal	The AUTOCAL function matches the controller to the current and voltage signals that are present in the system. The required calibration temperature can be set with the "UP" and "DOWN" keys. Pressing the "ENTER" key stores the set value and starts the "AUTOCAL" function. The word "- Calibration -" appears on the display while the AUTOCAL function is executing and a counter counts down from 15 to 0. When the controller has been calibrated successfully, the display switches back directly to the home position providing the "AUTOCOMP" function is deactivated. If "AUTOCOMP" is active, the display jumps to step 108. If the controller cannot be calibrated, the AUTOCAL function is aborted and an error message is displayed instead.	0...40 °C

No.	Name	Description	Setting range
108	Autocomp	Pressing the "ENTER" key starts the "AUTOCOMP" function. If the "ENTER" key is not pressed within 2s, the display returns to the home position. The home position is automatically displayed if the "AUTOCAL" function is successfully executed and "AUTOCOMP" is active.	
201 [20]	Language	The desired display language can be selected with this menu step.	English German Italian Software revision 015 or higher also: French, Spanish, Dutch, Danish, Finnish, Swedish, Greek, Turkish. Software revision 024 or higher also: Portuguese.
202 [21]	Factory settings	The controller can be reset to the factory settings by pressing the "ENTER" key (↵ section 11 "Factory settings" on page 46). In addition, as of software revision 100: The "UP" and "DOWN" keys can be used to select whether <ul style="list-style-type: none"> • The controller should be reset to the ROPEX factory settings • The current configuration should be specified as the default setting • The controller should be reset to a previously specified default setting 	

No.	Name	Description	Setting range
22	Alloy/range	<p> This step in the Configuration menu is available up to software revision 027 only.</p> <p>Various heatsealing band alloys and temperature ranges can be selected here. The corresponding characteristic for the controller parameters is calculated on the basis of this setting.</p> <p> Please be very careful to select the heat-sealing band material with the correct alloy.</p> <p>The temperature range setting permits the controller to be matched to the required operating range. This also determines the scale for the bar display.</p>	<p>(Availability depends on software revision)</p> <p>TCR 410ppm, 300°C TCR 460ppm, 300°C TCR 510ppm, 300°C TCR 570ppm, 300°C TCR 630ppm, 300°C TCR 700ppm, 300°C TCR 780ppm, 200°C TCR 780ppm, 300°C TCR 780ppm, 400°C TCR 780ppm, 500°C TCR 870ppm, 300°C TCR 980ppm, 300°C TCR 1100ppm, 200°C TCR 1100ppm, 300°C TCR 1100ppm, 400°C TCR 1100ppm, 500°C TCR 3500ppm, 200°C TCR 3500ppm, 300°C</p>
203	Alloy	<p>Various heatsealing band alloys can be selected here. The corresponding characteristic for the controller parameters is calculated on the basis of this setting.</p> <p> Please be very careful to select the heat-sealing band material with the correct alloy.</p>	<p>(Availability depends on software revision)</p> <p>TCR 780ppm TCR 1100ppm TCR 3500ppm variable</p>
204	Temperature coefficient	<p>If you selected "Variable" with step 203, you can specify the temperature coefficient of the heatsealing band material here in 10ppm increments using the "UP" and "DOWN" keys.</p>	400...4000ppm
205	Temperature range	<p>Various temperature ranges can be selected here. The temperature range setting permits the controller to be matched to the required operating range. This also determines the scale for the bar display.</p>	<p>200°C 300°C 400°C 500°C</p>
206 [23]	Maximum temperature	<p>This menu item specifies the maximum selectable set point (step 101 [1]) within the range defined by step 205 [22].</p>	0 to max. temperature range (step 205 [22])
213	Lock of "HAND" key	<p>You can specify here whether or not the heatsealing band can be heated in the home position by pressing the "HAND" key.</p>	ON, OFF
214 [24]	Cycle counter	<p>The number of heating impulses (not manual impulses) is counted and displayed with this menu step. The counter can be reset either by pressing the "ENTER" key or by restoring the factory settings.</p>	Reset with "ENTER" key

No.	Name	Description	Setting range
215 [25]	Alarm relay	This menu step permits the switching characteristics of the alarm relay to be configured. <ul style="list-style-type: none"> • Normal: The alarm relay output (terminals 5+6) operates as an NO contact in the event of a fault. • Inverse: The alarm relay output (terminals 5+6) operates as an NC contact in the event of a fault. 	Normal Inverse
217	Temperature diagnosis	If this value is set to "ON" and the actual temperature leaves the tolerance band (steps 207, 208), a fault signal indicating error code 307/308 is output.	OFF ON
218	Temperature diagnosis delay time	This delay time starts when the actual temperature enters the tolerance band. The temperature timeout and fault output are not activated until after the delay time has elapsed. This step can only be selected if the temperature diagnosis function (step 217) is active.	0...99.9s
219	Heatup timeout	If the actual temperature is outside the tolerance band when the specified time elapses (after the "START" signal has been activated), a fault signal indicating error code 304 is output.	OFF, 0...99.9s
220 [26]	Measuring impulse length	The length of the measuring impulse can be changed here. This function is only available with a few special applications (MOD 1).	1.7...3.0ms
221	Autocomp	Activates the „AUTOCOMP“ function	OFF, ON
225	Temperature unit	Unit for temperature display and input values	Celsius Fahrenheit

10.7 Temperature setting (set point selection)

The heatsealing temperature can be set on the RES-420 controller by means of the setting in menu step 101 [1].

! The maximum value of the setting range is limited either by the maximum value specified with step 206 [23] in the Configuration menu or by the heatsealing band type/temperature range set with step 205 [22].

The set point that is selected for the heatsealing temperature must be greater than 40°C. If not, the heatsealing band will not be heated up when the "START" signal is activated or the "HAND" key is pressed.

The set heatsealing temperature is displayed in the main menu once it has been entered.

10.8 Temperature indication

If the display is in the home position, the ACTUAL temperature is indicated there as a digital value and as a dynamic bar.

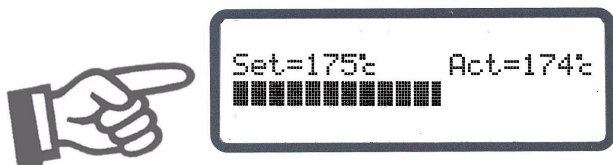

The heating and control process can thus be monitored at any time.

10.9 Automatic zero calibration (AUTOCAL)

Owing to the automatic zero calibration (AUTOCAL) function, there is no need to adjust the zero point manually on the controller. The "AUTOCAL" function matches the controller to the current and voltage signals that are present in the system.

You can activate this function by selecting step 107 [3] in the Settings menu and then pressing the "ENTER" key. The initial temperature (ambient temperature) of the heatsealing bar(s) which is currently valid for calibration can be set beforehand in the 0...40°C range using the "UP" and "DOWN" keys.

The zero point is calibrated in the factory to 20°C.

The automatic calibration process takes around 10...15 seconds. The heatsealing band is not heated until the calibration process has finished.

The message "- Calibration - Please wait..." appears on the display while the "AUTOCAL" function is executing and a counter counts down from 13 to 0.

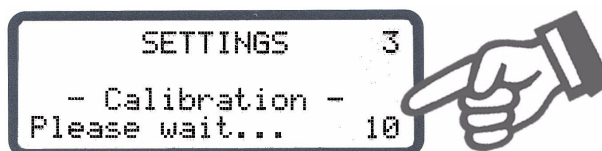

If the temperature of the heatsealing band varies on controllers as of software revision 100, the "AUTOCAL" function is executed a maximum of three times. If the function still cannot be terminated successfully, an error message appears (↪ section 10.24 "Fault areas and causes" on page 44).

! You should always wait for the heatsealing band and the bar to cool down (to ambient temperature) before activating the "AUTOCAL" function.

Reasons for disabled AUTOCAL function:

1. The "AUTOCAL" function cannot be activated if the heatsealing band cools down at a rate of more than 0.1K/second. This is additionally indicated with step 107 [3] in the Settings menu by the message "Heatsealing band still hot! Please wait...".
2. If the "START" signal (24VDC or contact) is activated, the AUTOCAL function is not executed. As of software revision 024 this is additionally indicated with step 107 [3] in the Settings menu by the message „Autocal locked ! (START-Sig. active)“.
3. Directly after the controller is powered up, the AUTOCAL function cannot be activated if a fault with error code 101...103, 201...203, 801 or 9xx occurs (↪ section 10.24 "Fault areas and causes" on page 44). If the controller has already operated correctly - a minimum of once - after powering up, the AUTOCAL function cannot be activated with error codes 201...203, 801 or 9xx.

10.10 "START" signal (HEAT)

When the "START" signal is activated, the controller-internal set/actual comparison is enabled immediately and the heatsealing band is heated up to the SET temperature. It remains at this temperature until the signal is deactivated again. This process can also be started

independently of the "START" signal by pressing the "ENTER" key ("HAND" function) while the main menu is displayed.

The "START" signal can be activated in two ways:

- By means of a 24VDC signal at terminals 3+4.

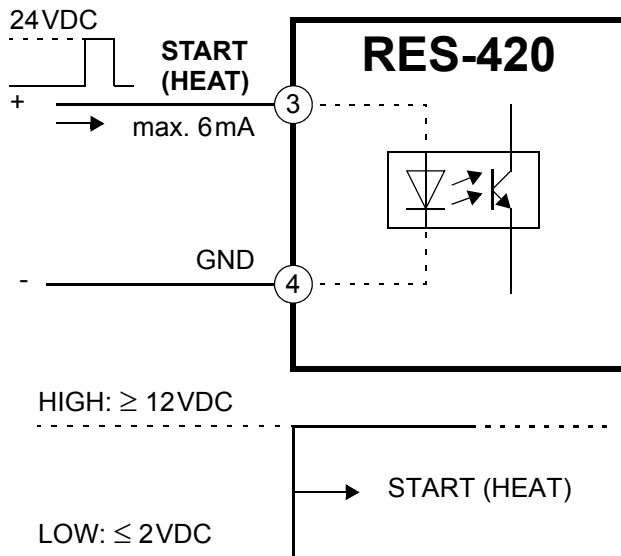

- By means of a control contact at terminals 2+7

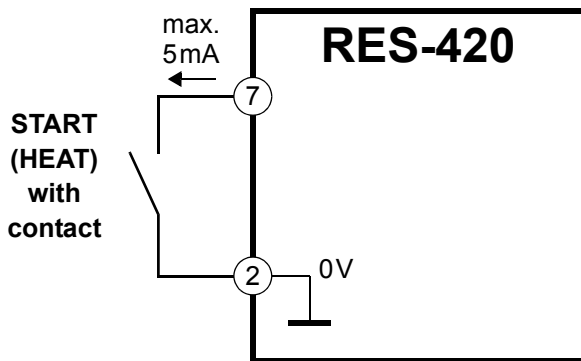

⚠ The "START" signal is disabled as long as the AUTOCAL function is executing in the Settings menu (with step 107 [3]).

The set point that is selected for the heatsealing temperature (step 101 [1] in the Settings menu) must be greater than 40°C. If not, the heatsealing band will not be heated up.

The alarm relay is switched if the "START" signal is activated while an error message is indicating error

codes 104...105, 111...113 or 211 (↪ section 10.24 "Fault areas and causes" on page 44). The heatsealing band is likewise not heated.

10.11 Cycle counter

Each activation of the "START" signal during operation is detected by a cycle counter integrated in the controller. Actuations of the "HAND" key are not counted. The counter reading can be displayed with step 214 [24] in the Configuration menu.

The cycle counter is reset to 0 if the "ENTER" key is pressed or if the maximum count of 999.999.999 cycles is exceeded.

10.12 Hold mode

The behavior of the digital indication of the ACTUAL temperature in the home position can be changed with step 106 [2] in the Settings menu. The following settings are possible:

1. **"OFF" (Factory setting)**
If the main menu is visible on the display, the real ACTUAL temperature is always indicated.
2. **"ON"**
If the display is in the home position, the ACTUAL temperature that was valid at the end of the last heatsealing phase is always indicated as a digital value. When the controller is switched on, the real ACTUAL temperature is indicated until the end of the first heating phase.
3. **"2 s" (Software revision 005 or higher)**
It causes the current ACTUAL temperature to be displayed as a digital value for an additional 2 seconds at the end of a heatsealing phase. This temperature is then indicated again in real time until the end of the next heating phase.

⚠ Hold mode only affects the digital value on the display. The ACTUAL temperature in real time is always indicated, regardless of the setting, by the dynamic bar.

The various hold modes are shown below:

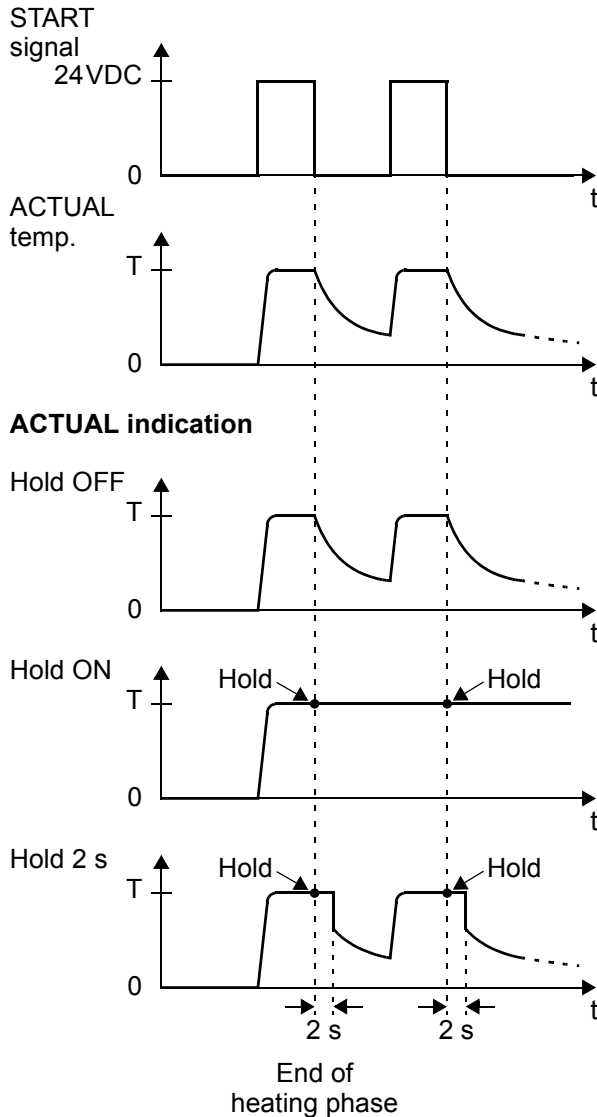

The word "Hold" appears on the display if a temperature value is indicated in hold mode. It disappears for approximately 100ms whenever the hold value is updated.



10.13 Measuring impulse duration (as of software revision 026)

The length of the measuring impulses generated by the controller can be set with this parameter by means of

step 220 [26]. It may be necessary to set a measuring impulse that is longer than the default 1.7 ms for certain applications (↪ ROPEX Application Report).

10.14 Automatic phase angle compensation (AUTOCOMP) (as of software revision 100)

It may be necessary to compensate the phase angle displacement between the U_R and I_R measuring signals in certain heatsealing applications (↪ ROPEX Application Report). The "AUTOCOMP" function is provided for this purpose. It can be parameterized with step 221 as followed:

1. „OFF“ (Factory setting)
The „AUTOCOMP“ function is deactivated.
2. „ON“
The „AUTOCOMP“ function is activated by pressing the "ENTER" key after the "AUTOCAL" function has been successfully executed (↪ section 10.9 "Automatic zero calibration (AUTOCAL)" on page 35). The interval after the end of the "AUTOCAL" function must be less than 2.0s ("Start AUTOCOMP? Start with ENTER" appears on the display during this time). The subsequent "AUTOCOMP" function is executed in approximately 2.0s (" - AUTOCOMP - Please wait..." appears on the display during this time).
If the interval following the successful execution of the "AUTOCAL" function is longer than 2.0s, the display returns to the home position and the "AUTOCOMP" function is not executed. The actual value

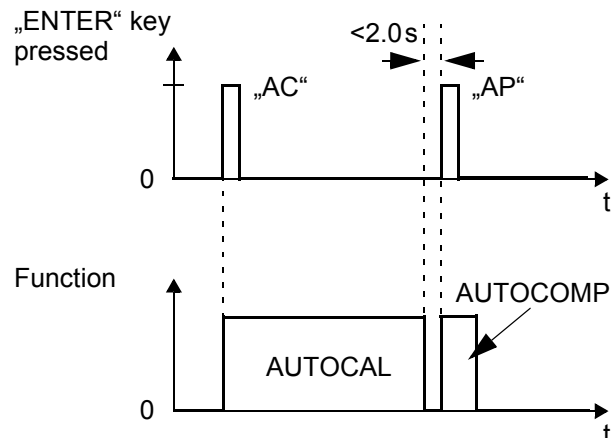

output is set to 0...3°C (i.e. approx. 0VDC) when the "AUTOCOMP" function is executed.

3. **„AUTO“**
(as of software revision 105)
With this setting the „AUTOCOMP“ function is activated automatically after the "AUTOCAL" function has been successfully executed.

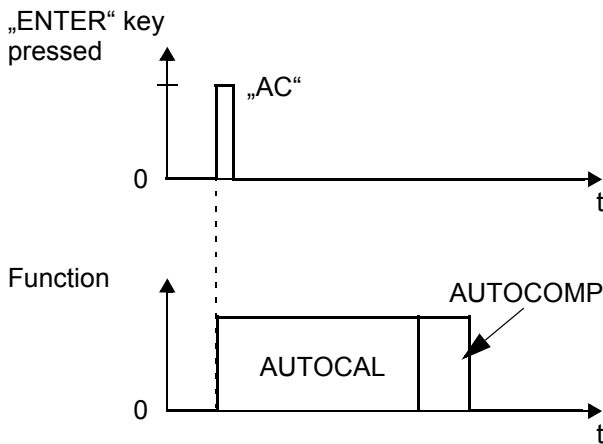

10.15 Locking the "HAND" key (as of software revision 100)

The "HAND" key function can be configured with step 213 in the Configuration menu when the display is in home position. This prevents the heatsealing bands from being heated if the "HAND" key is pressed inadvertently. The following settings are possible:

1. Lock **„OFF“** (Factory setting)
Pressing the "HAND" key while the display is in the home position starts a manual heating process. The heatsealing band is heated as long as the "HAND" key remains pressed.
2. Lock **„ON“**
The "HAND" key is locked when the display is in the home position, in other words it has no function.

10.16 Temperature unit Celsius / Fahrenheit (as of software revision 106)

As of software revision 106 the unit for the temperature indication and value selection can be switched between °C (Celsius) and °F (Fahrenheit). It can be parameterized with step 225 as followed:

1. **„Celsius“** (Factory setting)
Temperature indication and value selection in Celsius (°C).

2. **„Fahrenheit“**
Temperature indication and value selection in Fahrenheit (°F)
Up to software revision 105 only Celsius (°C) can be specified on the controller as the temperature unit.

- The degree unit can be changed on the controller without interrupting operation**
- If you specify temperature indication and value selection in Fahrenheit (°F), the controller still uses Celsius (°C) internally. Value steps are therefore possible with this function owing to the conversion from Celsius to Fahrenheit.**

10.17 Disabling the Configuration menu

(Software revision 010 or higher)
It is possible to disable all changes to values/parameters in the Configuration menu. This prevents the controller configuration from being tampered with by unauthorized persons. The Configuration menu can be disabled or enabled by pressing the "MENU" key for 2.0seconds while the power-up message is displayed (after switching on the controller, see section 10.2.1 "Power-up message" on page 25). The display then shows a message confirming that the disable function is active for 3.0seconds before returning to the home position.



The same message is also displayed for 5.0seconds when you open the Configuration menu to indicate that this menu is disabled.

- You can still display all steps, values and parameters even if the Configuration menu is disabled. You are no longer allowed to enter or change values, however.**
- As of software revision 103 the language in menu pos. 201 can be changed while the configuration menu is locked (see section 9.3.2 "Setting the language" on page 20).**

The Configuration menu remains disabled until the disable function is canceled again. To do so, repeat the above procedure (press the "MENU" key for

2.0 seconds while the power-up message is displayed). The display then shows a message confirming that the disable function has been canceled.

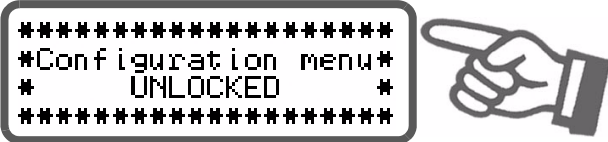

In the factory setting the Configuration menu is not disabled.

10.18 Setting the display brightness (VF display only)

(Software revision 019 or higher)

If the display is in the home position, the brightness of the VF display (blue) can be set in 4 steps (25%, 50%, 75%, 100%) with the "UP" and "DOWN" keys. The factory setting is 75%.

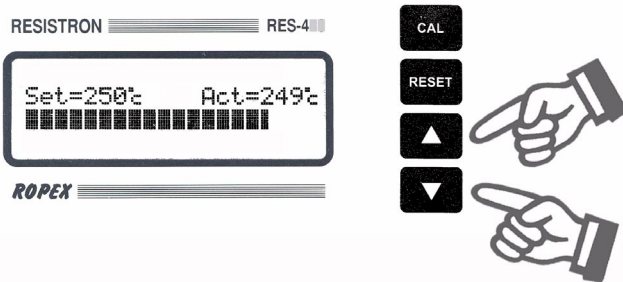

The life of the VF display can be prolonged by reducing the brightness.

10.19 Undervoltage detection

Trouble-free operation of the temperature controller is guaranteed within the line voltage tolerance range specified in section 6 "Technical data" on page 9. If a line voltage which is less than the lower limit of the permissible range occurs, the controller is switched to a standby mode. No more heatsealing processes take place and no more measuring impulses are generated. The display changes to indicate this.

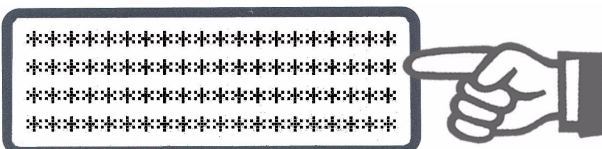

The main menu is displayed again, and operation is resumed, when the input voltage returns to the specified tolerance range.

The alarm relay (terminals 5+6) is only switched by an undervoltage condition in controllers up to and including software revision 008. The alarm relay in controllers with a higher software revision number is not switched if an undervoltage condition occurs.

! Trouble-free operation of the controller is only guaranteed within the specified input voltage tolerance range. An external voltage monitor must be connected to prevent defective heatseals as a result of low line voltage.

10.20 Diagnostic interface/visualization software (as of software revision 100)

An interface with a 6-pole Western socket is provided for systemdiagnostics and process visualization. This interface allows a data connection to be set up to the ROPEX visualization software using the ROPEX communication interface CI-USB-1.

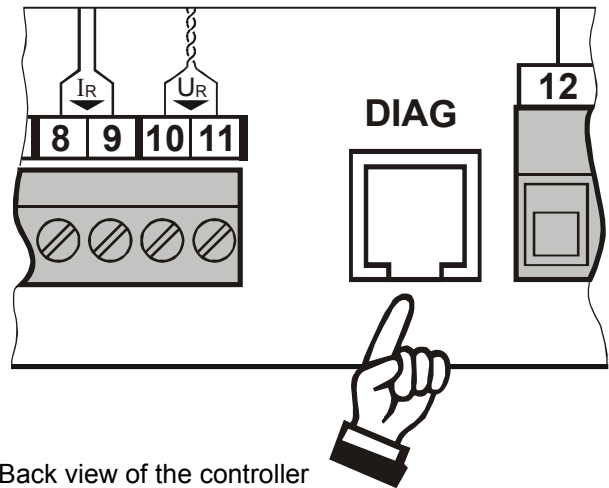

Back view of the controller

! Only a ROPEX communication interface is allowed to be connected to the diagnostic interface. Connecting another device (e.g. a telephone cable) could result in malfunctions or damage to the controller.

The ROPEX visualization software is described in a separate document.

10.21 Booster connection

The RES-420 controller has a connection for an external switching amplifier (booster) as standard. This connection (at terminals 1+2) is necessary for high primary currents (continuous current > 5A, pulsed current > 25A). The switching amplifier should be connected as described in section 8.7 "Wiring diagram with booster connection" on page 17. No settings are required in the menu.

10.22 System monitoring/alarm output

To increase operating safety and to avoid faulty heatsealing, the controller incorporates special hardware and software features that facilitate selective fault detection and diagnosis. Both the external wiring and the internal system are monitored. These features crucially support the system owner in localizing the cause of an abnormal operating state. A system fault is reported or differentiated by means of the following elements.

A.) Error message on the display:



The cause of a fault can be localized quickly and easily with the help of the error code that appears on the display. Please refer to section 10.24 "Fault areas and causes" on page 44 for a list of the possible error codes.

B.) Alarm relay (relay contact, terminals 5+6):

This contact is set in the factory as follows:

- **OPEN** if error code 104...106, 111...113 or 211 is displayed. The contact closes, however, if a "START" signal is activated in this state.
- **CLOSED** if error code 101...103, 107, 108, 201...203, 801 or 9xx appears.

If the alarm relay is configured differently from the factory setting (↪ section 9.3.9 "Configuration of the alarm relay" on page 22), these states are inverted.

! An error message can only be reset by pressing the "RESET" key or by switching the controller off and then on again.



! Invalid error messages may appear when the controller is switched off owing to the undefined operating state. This must be taken into account when they are evaluated by the higher-level controller (e.g. a PLC) in order to avoid false alarms.

10.23 Error messages

The table below describes each fault and the required corrective action. The block diagram in section 10.24 "Fault areas and causes" on page 44 permits each fault to be cleared quickly and efficiently. The error codes described below can also be displayed in the ROPEX visualization software (↪ section 10.20 "Diagnostic interface/visualization software (as of software revision 100)" on page 39) to facilitate troubleshooting.

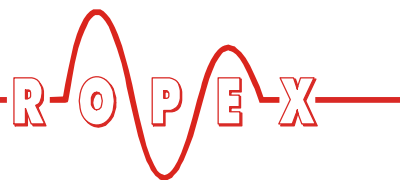

Part 1 of 3:					
Error code	STATUS of alarm relay (factory set.)	Cause	Action if machine started for first time	Action if machine already operating, HS band not chang.	
1	Closed	I _R signal missing	Fault area ①	Fault area ①	
2		U _R signal missing	Fault area ③	Fault area ③	
3		U _R and I _R signals missing	Fault area ②	Fault area ②⑨	
107 108		Temperature step, down Temperature step, up	Fault area ④⑤⑥ (loose contact)	Fault area ④⑤⑥ (loose contact)	
4		307 308 309 310	Temperature too low/high (↘ section 9.3.7)		
5		201 202 203	Frequency fluctuation, inadmissible line frequency	Check power supply	Check power supply
6		304	Heatup time too long (↘ section 9.3.8)	Run RESET	Run RESET
7		901 913 914 915 916	Int. fault, contr. defective Triac defective Int. fault, contr. defective Int. fault, contr. defective Int. fault, contr. defective	Replace controller Replace controller Replace controller Replace controller Replace controller	Replace controller Replace controller Replace controller Replace controller Replace controller
917 918			Plug-in jumper for alarm relay wrong	Check plug-in jumper	Check plug-in jumper

Part 2 of 3:					
NOTE: The specified error messages are initially output as warnings (alarm relay is open) When the "START" signal is activated, the warning changes to a fault (alarm relay is closed).					
Error code	STATUS of alarm relay (factory set.)	Cause	Action if machine started for first time	Action if machine already operating, HS band not chang.	
104	Warning: Open Fault: Closed (voltage value at actual value output then no longer changes)	I _R signals incorrect, incorrect specification of impulse-transformer	Run AUTOCAL , Check specification of transformer, Fault area ⑦⑧	Fault area ④⑤⑥ (loose contact)	
105		U _R signals incorrect, incorrect specification of impulse-transformer			
106		U _R and/or I _R signals incorrect, incorrect specification of impulse-transformer	Run AUTOCAL and/or fault area ④⑤⑥ (loose contact)		
302 (AC)		Temperature too low, AUTOCAL wasn't performed, loose contact, ambient temp. fluctuates			
303 (AC)		temperature too high, AUTOCAL wasn't performed, loose contact, ambient temp. fluctuates			
211		Data error	Run AUTOCAL		
8					
9					

Part 3 of 3:					
<p>NOTE: The specified error messages are initially output as warnings (alarm relay is open) When the "START" signal is activated, the warning changes to a fault (alarm relay is closed).</p>					
Error code	STATUS of alarm relay (factory set.)	Cause	Action if machine started for first time	Action if machine already operating, HS band not chang.	
10	Warning: Open	I _R signal incorrect, calibration not possible	Fault area ⑧, check configuration	---	
11		U _R signal incorrect, calibration not possible	Fault area ⑦, check configuration	---	
12		U _R and I _R signals incorrect, calibration not possible	Fault area ⑦⑧, check configuration	---	
13	Fault: Closed (voltage value at actual value output then no longer changes)	Temperature fluctuates, calibration not possible			
		Ext. calibration temperature too high,			
		Ext. calibration temperature fluctuates			
111					
112					
113					
114					
115					
116					

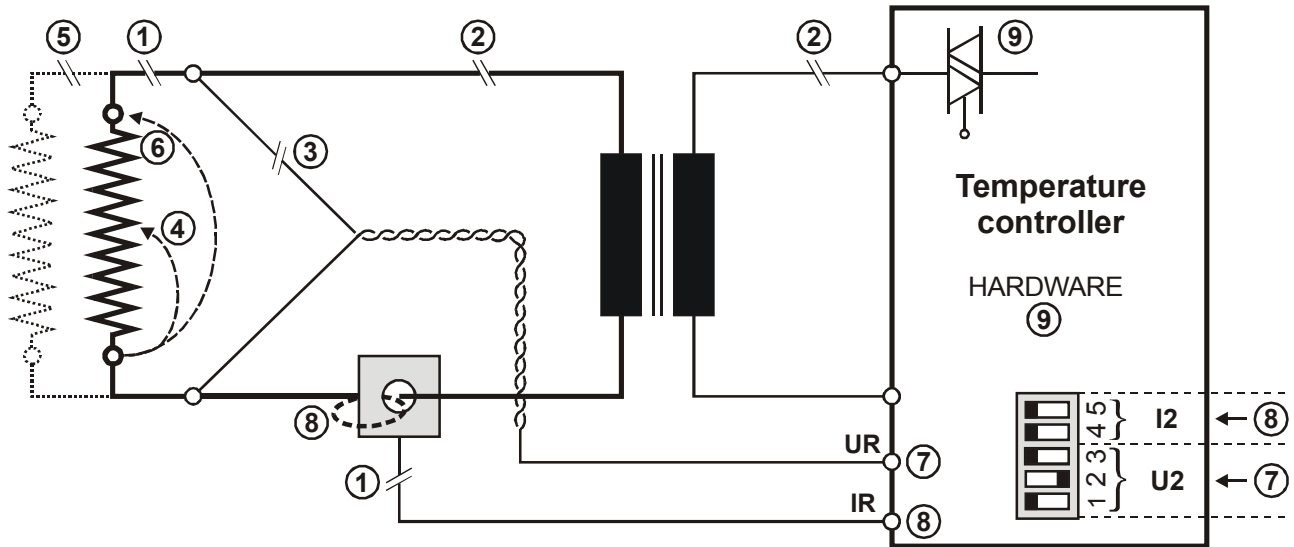
10.24 Fault areas and causes

The table below explains the possible fault causes.

Fault area	Explanation	Possible causes
①	Load circuit interrupted after U_R pickoff point	- Wire break, heatsealing band break - Contacting to heatsealing band defective
	PEX-W2/W3 current transformer signal interrupted	- I_R measuring wire from current transformer interrupted
②	Primary circuit interrupted	- Wire break, triac in controller defective - Primary winding of impulse transformer interrupted
	Secondary circuit interrupted before U_R pickoff point	- Wire break - Secondary winding of impulse transformer interrupted
③	U_R signal missing	- Measuring wire interrupted
④	Partial short-circuit (ΔR)	- Heatsealing band partially bypassed by conducting part (clamp, opposite heatsealing bar etc.)
⑤	Parallel circuit interrupted	- Wire break, heatsealing band break - Contacting to heatsealing band defective
⑥	Total short-circuit	- Heatsealing band installed incorrectly, insulation at heatsealing bar ends missing or incorrectly installed - Conducting part bypasses heatsealing band completely
⑦	U_R signal incorrect	- Up to software revision 027: DIP switches 1 - 3 configured incorrectly (U_2 range) - As of software revision 100: U_2 outside permissible range from 0.4...120VAC

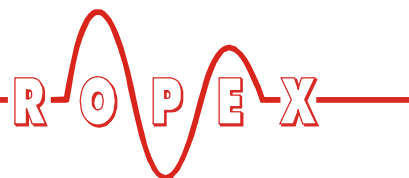

Fault area	Explanation	Possible causes
⑧	I _R signal incorrect	<ul style="list-style-type: none"> - Up to software revision 027: DIP switches 4+5 configured incorrectly (I₂ range) - As of software revision 100: I₂ outside permissible range from 30...500A
	Turns through PEX-W2/W3 current transformer incorrect	<ul style="list-style-type: none"> - Check number of turns (two or more turns required for currents < 30A)
⑨	Internal controller fault	<ul style="list-style-type: none"> - Hardware fault (replace controller)

11 Factory settings

The RESISTRON temperature controller RES-420 is configured in the factory as follows:

<p><u>DIP switches</u> for secondary voltage U_2 and current I_2 (Up to software revision 027)</p>		<p>$U_2 = 6...60VAC$ $I_2 = 30...100A$</p> <p>DIP switches: 2 ON 1, 3, 4, 5 OFF</p> <p>These switches are automatically set by the AUT-ORANGE function on all controllers as of software revision 100.</p>
<p><u>Settings menu</u></p>	<p>No. 101 [1] Heatsealing temperature: 0°C No. 106 [2] Hold mode: OFF No. 107 [3] AUTOCAL temperature: 20°C</p>	
<p><u>Configuration menu</u></p>	<p>No. 201 [20] Language German This selection is NOT changed if the factory settings are restored with step 202 [21] in the Config. menu.</p> <p>No. 203, 204 [22] Alloy/range: Alloy-20/max. 300°C</p> <p>No. 206 [23] Maximum temperature: 300°C No. 213 Lock of „HAND“ key OFF No. 214 [24] Cycle counter: 0 No. 215 [25] Alarm relay: Normal (contact closed by a fault) No. 217 Temperature diagnosis: OFF No. 218 Temp.diagnosis delay time: 0s No. 219 Heatup timeout: OFF No. 220 [26] Measuring impulse length: Standard (1.7 ms) No. 221 Autocomp: OFF No. 225 Temperature unit: Celsius</p>	

Up to software revision 027:
The controller can be reset with step 21 in the Configuration menu:

The factory settings are restored if the "ENTER" key is pressed. An acknowledgment message is displayed for approximately 2s.

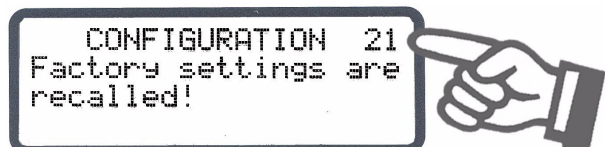
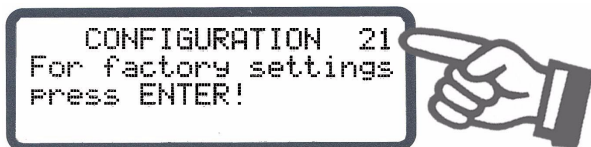

⚠ The language which is selected with step 20 in the Configuration menu remains set even if the factory settings are restored.

11.1 Customer settings (as of software revision 100)

The controller factory settings can be specified or restored with step 202 in the Configuration menu. You can also store customer settings in addition to the Ropex settings:

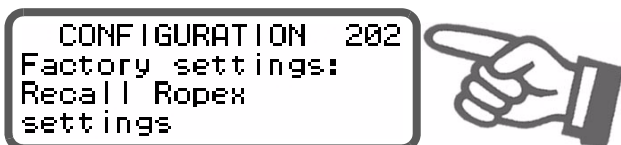

The following settings are possible:

1. „Restore Ropex settings“ (Factory setting)

Selecting this option restores the menu values listed in section 11 "Factory settings" on page 46. These values correspond to the factory settings with which the controller was delivered.

2. „Define customer settings“

Selecting this option saves the values that are currently set in the controller Settings and Configuration menus as "customer settings". These "customer settings" are independent of the Ropex settings. Machine-specific settings can be stored in the controller in this way.

3. „Restore customer settings“

Selecting this option restores the "customer settings" that were saved as described in 2.

 **When the controller is first delivered, the "customer settings" are identical to the Ropex settings.**

After pressing the "ENTER" key in this menu step, you are asked to confirm the new settings (safety query).

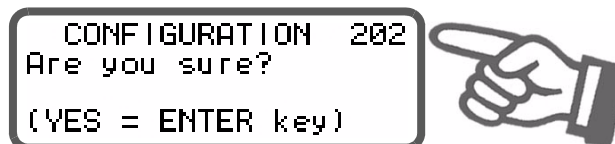

Another message appears if you now confirm these settings by pressing the "ENTER" key for approximately 2seconds.

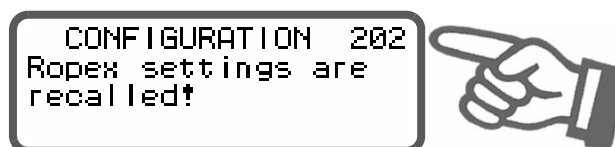

You can also cancel the new settings by pressing the "MENU", cursor "UP" or cursor "DOWN" keys. Step 203 then appears on the display.







 **The language which is selected with step 201 in the Configuration menu remains set even if the previous settings are restored.**

12 Maintenance

The controller requires no special maintenance. Regular inspection and/or tightening of the terminals – including the terminals for the winding connections on

the impulse transformer – is recommended. Dust deposits on the controller can be removed with dry compressed air.

13 How to order

	<p>Contr. RES - 420- . / . . . VAC</p> <ul style="list-style-type: none"> L / 115: LC display, line voltage 115VAC, Art. No. 742011 L / 230: LC display, line voltage 230VAC, Art. No. 742012 L / 400: LC display, line voltage 400VAC, Art. No. 742013 V / 115: VF display, line voltage 115VAC, Art. No. 742021 V / 230: VF display, line voltage 230VAC, Art. No. 742022 V / 400: VF display, line voltage 400VAC, Art. No. 742023 <p>Scope of supply: Controller includes connector plug-in parts (current transformer must be ordered separately)</p> <p>Modification MOD . . (optional, if required)</p> <ul style="list-style-type: none"> e.g. 01: MOD 01, Art. No. 800001 (amplifier for low voltage) <p>Please indicate the article numbers of the controller and the required modifications (optional) in all orders, e.g. RES-420-L/400VAC + MOD 01 (controller with LC display for 400VAC line voltage and amplifier for low voltage) Art. Nos. 742013 + 800001 must be ordered</p>
	<p>Current transformer PEX-W3 Art. No. 885105</p>
	<p>Line filter LF- . . 480</p> <ul style="list-style-type: none"> 06: Continuous current 6A, 480VAC, Art. No. 885500 35: Continuous current 35A, 480VAC, Art. No. 885506
	<p>Impulse transformer</p> <p>See ROPEX Application Report for design and ordering information</p>
	<p>Communication interface CI-USB-1 Art. No. 885650</p>
	<p>Booster B- . . . 400</p> <ul style="list-style-type: none"> 075: Max. pulse load 75A, 400VAC, Art. No. 885301 100: Max. pulse load 100A, 400VAC, Art. No. 885304

For more accessories: ↗ "Accessories" leaflet

14 Index

A

Accessories 7
 Adapter for top hat rail mounting 8
 Alarm output 40
 Alarm relay 10, 22
 Alloy 20, 21, 24
 Ambient temperature 10
 Application 4
 Application Report 12, 15, 19
 AUTOCAL 6, 23, 35
 AUTOCOMP 37
 Automatic phase angle compensation 37
 Automatic zero calibration 6, 23, 35
 AUTOTUNE 6

B

Booster 7, 17, 48
 Booster connection 40
 Burning in heatsealing band 22, 24

C

Celsius °C 38
 Circuit breaker 14
 CI-USB-1 7, 39, 48
 Communication interface 7, 39, 48
 Controller configuration 19
 Controls 24
 Current transformer 7, 15, 48
 Customer settings 47
 Cycle counter 36

D

Degree of protection 10
 Diagnostic interface 39
 Dimensions 11
 DIP switches 19
 Disabling Configuration menu 38
 Display 25
 Display brightness 39

E

Error messages 40
 External switching amplifier 7, 17

F

Factory settings 20, 46
 Fahrenheit °F 38
 Fault areas 44
 Fault diagnosis 6
 Front cover 7

H

HEAT 23, 35

Heatsealing band type 9
 Heatup timeout 22
 Hold mode 36

I

Impulse heatsealing method 4
 Impulse transformer 7, 14, 48
 Installation 10, 12
 Installation procedure 12
 Installation regulations 12

L

Line filter 7, 14, 15, 48
 Line frequency 6, 9
 Line voltage 9
 Locking the "HAND" key 38

M

Maintenance 47
 Manual mode 35
 Measurement cable 8
 Measuring impulse duration 37
 Modifications 8, 48
 MODs 8, 48
 Monitoring current transformer 7

O

Overheating of heatsealing band 6

P

PEX-W2/-W3 3
 PEX-W3 15, 48
 Phase angle compensation 37
 Power dissipation 10
 Power supply 14
 Principle of operation 5

R

Replacing heatsealing band 22, 24

S

Secondary current I_2 19
 Secondary voltage U_2 19
 Set point selection 9, 35
 Standby mode 39
 "START" signal 23, 35
 System diagnostics 39
 System monitoring 40

T

TCR 3, 22
 Temperature coefficient 3, 21, 22

Temperature control 4
Temperature diagnosis 21
Temperature indication 35
Temperature range 9, 20, 21
Temperature setting 35
Temperature unit 38
Transformer 3, 7, 14, 48
Type of construction 9

U

Undervoltage detection 39

V

View of controller 18
Visualization software 39

W

Wiring 12, 14
Wiring diagram 16, 17