

NSE10-SN/SL

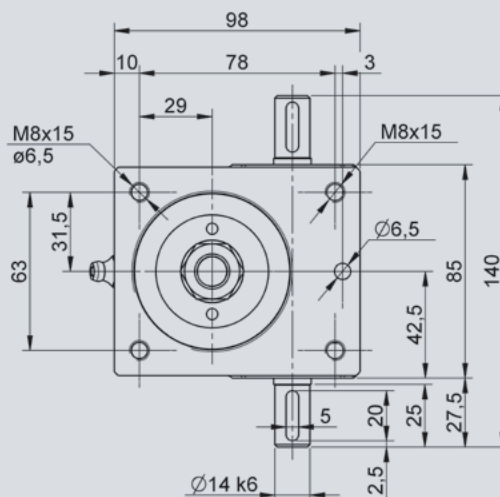
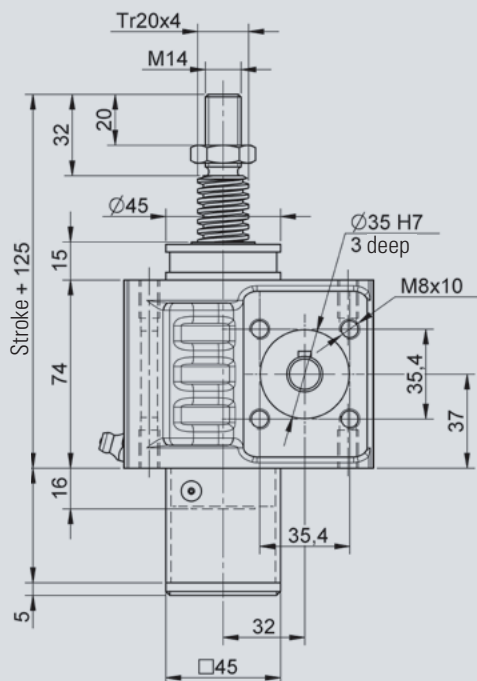
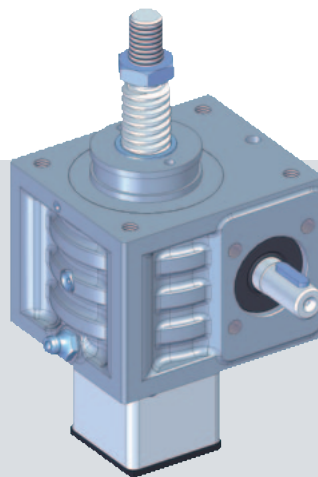

The innovative modular screw jack system from Nozag, allows for perfect drive solutions from low cost standard components. The kit is subject to the highest standards of functionality, quality and design. With little effort, very much can be moved and still, the investment, maintenance and operating costs are kept within narrow limits.

Screw jacks developed and produced by Nozag, solve these tasks in a simple and cost efficient manner.

Specifications

Maximum lifting capacity	10 kN (1000 kg)
Maximum driveshaft speed	1400 min ⁻¹ (higher on request)
Spindle	TR 20/4 (standard)

Material

Material (housing):	Aluminium
Lubrication:	Grease

Weight

Screw jack weight:	1.98 kg (with grease / without spindle)
Spindle weight:	2.00 kg/m

Features

Type	Ratio i	Stroke per revolution mm	Driving torque ¹ Nm	Max torque Nm	Drive through torque ² Nm
NSE10-SN	4:1	1.00	F(kN) x 0.46 + 0.26	10.50	42
NSE10-SL	16:1	0.25	F(kN) x 0.14 + 0.16	4.20	42

1) Factor includes efficiency, ratio and safety 1

	Basis	Options
Spindle length		
Stroke:	
Safety clearance (spindle pitch)	+ 4	
Basis Length	+137	
Escape protection		+ 15
Lock against rotation		+ 15
Safety clearance (spindle pitch)	+ 4	
Compressed length of bellows	

Overall length of spindle = + =

Compressed length of bellows

$\text{Stroke} / 24.5 = \dots \times 3.5 = \dots$
(round number)

Protective tube

Stroke	
Basis length	+ 21	
Escape protection		+ 34
Lock against rotation		+ 34

Total protection tube length = + =

2) By more that six gearboxes in series, please contact our technicians

Buckling

(Load case-Spindletype)

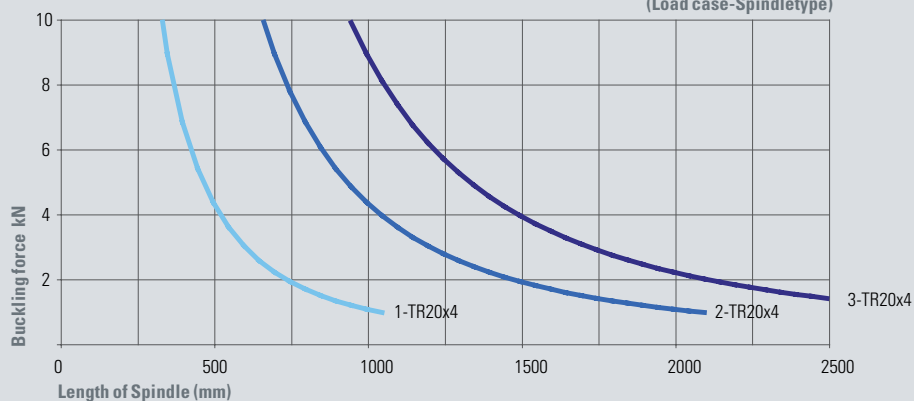

Load case



Determine, in the diagram (calculated with safety 1), with the corresponding load case (1 / 2 / 3), the intersection of the buckling force F and free spindle length L . The intersection point must lie below the boundary line of the chosen spindle diameter. If not, a bigger spindle, respectively, the next larger gearbox is to be selected.

We reserve the right on printing and dimension errors, as well as technical changes and improvements.

CAD files can be downloaded at www.nozag.ch.

Attachments



- 1 Spindle
- 2 Escape protection
- 3 Lock against rotation
- 4 Mounting flange
- 5 Fork head
- 6 Ball joint head
- 7 Swivel bearing head
- 8 Suspension adapter for gearboxes
- 9 Protection cap
- 10 Bellows
- 11 Spiral spring cover
- 12 Lubricant dispenser
- 13 Hand wheel

Drive components

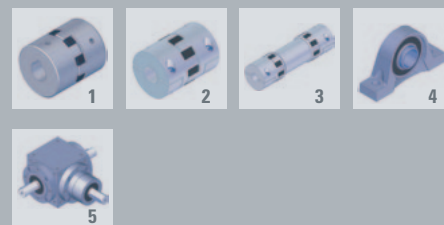

- 1 Coupling
- 2 Clamp coupling
- 3 Connecting shaft
- 4 Pedestal bearing
- 5 Bevel gearboxes

Motor mounting



- 1 Motor adapter
- 2 Motor / brake motor
- 3 Rotary pulse encoder
- 4 Spring brake

Refer to the catalog system program, for attachments, drive components and motor mountings.

Available on request:

- > Double-threaded trapezoidal screw
- > Ballscrew
- > Stainlesssteel spindle (INOX)
- > Surface-treated spindle