

piccolo™

Temperature and Process Controllers

Outstanding performance in an affordable package



Eurotherm®

by **Schneider** Electric

Control Optimise Simplify

Outstanding performance in an affordable package

Improve process efficiency, product quality and minimise waste with our high accuracy controllers. These feature-rich instruments offer versatility in application and have clear, user friendly operator interfaces. Quickstart features, help text and PC graphical wiring ensure your engineering costs are minimised even with the most sophisticated of configurations.

Designed around the needs of the 21st Century working environment to create a reliable and easy to apply unit, the piccolo™ controller works with you to help you achieve your day to day objectives for yield and cost. Wherever in the world you or your process is located, you can profit from the vast experience Eurotherm has gained over more than 50 years as a world leading temperature and process control specialist.



Easy to commission – easy to use – easy to own

Easily Achieved Benefits

- **Reliable easy to use** – the piccolo temperature controller works to help achieve day-to-day objectives for yield and cost
- **Improve quality** – precise stable control means that your process stays within your quality limits

Easy to commission

- Rapid set up with Quick Code configuration
- Customisation of lists and settings with PC based Wizard
- Standard panel cut outs in DIN sizes
- Comprehensive support by phone or email
- Recovery point simplifies support by ensuring that any operator can quickly revert the controller to known settings



Easy to use

With an established track record of reliability backed by a global service network, Eurotherm offers the peace of mind provided by a quality product.

- 3 year standard warranty
- Telephone and e-mail support
- Formal site service support and calibration arrangements
- Full range of industry certificates, including CE, cUL, RoHS

Global availability and support

As a global market leader, Eurotherm offers its products via an extensive worldwide distribution network. If you need a controller fast, our global sales and distribution network is best positioned to help you. Our commitment to you for quality and reliability is backed by the support capability and the expertise of a true specialist.

Easy to own

In global businesses where manufacturing operations may take place anywhere in the world, it is vital that instrument operators can quickly learn to operate key process steps without risk of errors.

- Simple, customisable settings with security for different levels of personnel
- Local and remote setpoint control and alarm acknowledgement
- High visibility 3 colour display with just the information you need to see

Aids continuous improvement against targets

An increasingly competitive world means constant pressure on margins and an ongoing need to improve the process efficiency. What often stands in the way of continuous improvement is the difficulty of obtaining performance data from older control systems. With the Eurotherm piccolo controller you can easily access process metrics, without the need to change your entire control system.

- Accurate measurements of process deviation from setpoint
- Energy usage estimates for electrical loads
- Measurements easily available over digital communications or on front panel

Easy to integrate

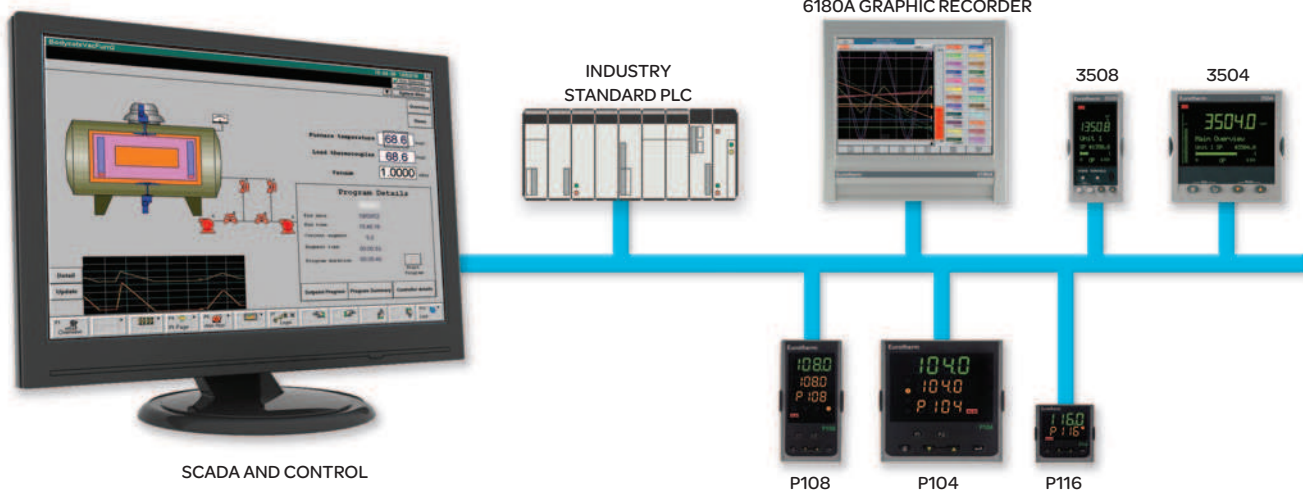

The perfect fit for OEM applications

Eurotherm works in partnership with many world leading OEM customers, providing state-of-the-art control capability in surprisingly affordable formats.

In crowded equipment markets your products must stand out from your competitors – and the piccolo controller provides a hugely flexible platform to help you achieve this. From configurable HMI lists through branded front fascias to fully customised firmware, Eurotherm can help you differentiate your products with a top quality control component.

We pride ourselves on exceptional on-time delivery performance. Our flexible and lean manufacturing operations will ensure that we can supply the components you need to feed your growth when you need them. Controllers can be supplied fully configured and to aid speedy commissioning our product can be supplied preconfigured to your application needs.

With a growing range of global industry certifications and approvals, we provide the peace of mind of a single supplier solution, wherever in the world you choose to do business.

Where your own reputation rests on quality, reliability and performance, Eurotherm should be your partner of choice. Call us to discuss how we can provide an unbeatable package.

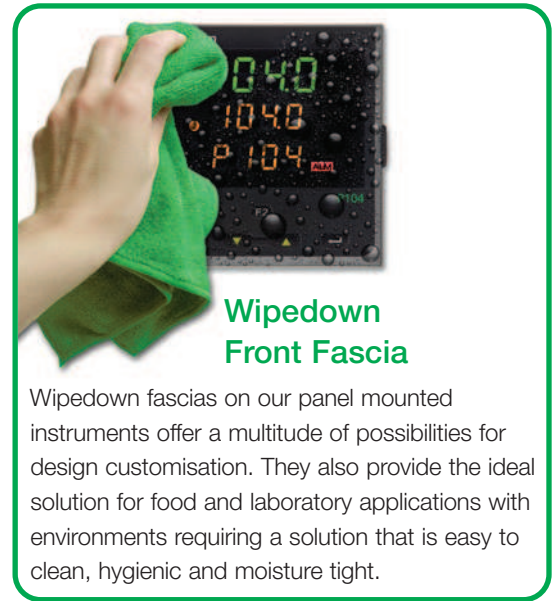

Wipedown Front Fascia



Wipedown fascias on our panel mounted instruments offer a multitude of possibilities for design customisation. They also provide the ideal solution for food and laboratory applications with environments requiring a solution that is easy to clean, hygienic and moisture tight.

Space Saving

Where space is at a premium, the compact size with a depth of only 90mm provides significant space savings.



Selection guide

piccolo controller			
	P116	P108	P104
Panel size (DIN)	1/16	1/8	1/4
IP Rating	IP66 NEMA Type 12	IP66 NEMA Type 12	IP66 NEMA Type 12
Display Type	Main: 4 digits Lower: Secondary 4 digits, amber	Main: 4 digits Lower: Secondary 4 digits, amber Third: 4 digits, amber	Main: 4 digits Lower: Secondary 4 digits, amber Third: 4 digits, amber
Supply Voltage	24V ac/dc 100-230V ac	24V ac/dc 100-230V ac	24V ac/dc 100-230V ac
Input Type	TC, RTD, mV, mA, CT	TC, RTD, mV, mA, CT	TC, RTD, mV, mA, CT
PV Accuracy	<0.25%	<0.25%	<0.25%
Control Types	On/Off, PID	On/Off, PID	On/Off, PID
Special Features	Energy Monitoring, Recovery Point	Energy Monitoring, Recovery Point	Energy Monitoring, Recovery Point
Timer Functions	Ramp/Soak, Delay, Soft Starter	Ramp/Soak, Delay, Soft Starter	Ramp/Soak, Delay, Soft Starter
Analogue IP/OP	In: 2 Out: 1	In: 2 Out: 1	In: 2 Out: 1
Digital IP/OP	In: 1 Out: 3	In: 2 Out: 4	In: 2 Out: 4
Digital Comms	Modbus RTU – RS485	Modbus RTU – RS485	Modbus RTU – RS485
Alarm Types	Hi, Lo, Dev, Sensor break, Event, Heater fail	Hi, Lo, Dev, Sensor break, Event, Heater fail	Hi, Lo, Dev, Sensor break, Event, Heater fail
Industry Certifications	CE, cUL, RoHS 2, EN14597 TR, CCC Exempt, CU-TR (GOST)	CE, cUL, RoHS 2, EN14597 TR, CCC Exempt, CU-TR (GOST)	CE, cUL, RoHS 2, EN14597 TR, CCC Exempt, CU-TR (GOST)
PC Configuration	Wizard/Eurotherm iTools	Wizard/Eurotherm iTools	Wizard/Eurotherm iTools

Typical Order Codes

To order a piccolo controller with the most common configuration, including a logic SSR drive and two mains rated relays for control or alarm as well as RS485 digital communications for setup and monitoring, specify:

P116/CC/VH/LRX/R/4CL	1/16 DIN Compact 48mm High x 48mm Wide x 90mm Deep panel format
P108/CC/VH/LRR/R/4CL	1/8 DIN Compact 96mm High x 48mm Wide x 90mm Deep panel format
P104/CC/VH/LRR/R/4CL	1/4 DIN Compact 96mm High x 96mm Wide x 90mm Deep panel format

Rear Terminals

Comprehensive range of Input/Output options

As you would expect from an Eurotherm controller, a full range of input and output options are supported. Full galvanic isolation is provided between the main measurement input and external functions such as communications for safety and reliability.

- **Input Type** Thermocouple, resistance thermometer and mV input. Current and voltage measurements available via external shunt
- **Outputs** Relay, SSR logic drive, triac and 4-20mA DC outputs
- **Digital Inputs** Contact closure logic inputs to switch a wide range of instrument functions
- **Current Transformer** For current measurement energy estimation calculations, and heater health diagnostics
- **Communications** Industry standard RS485 Modbus RTU communications
- **Supply Voltage** Wide ranging ac/dc power supply options

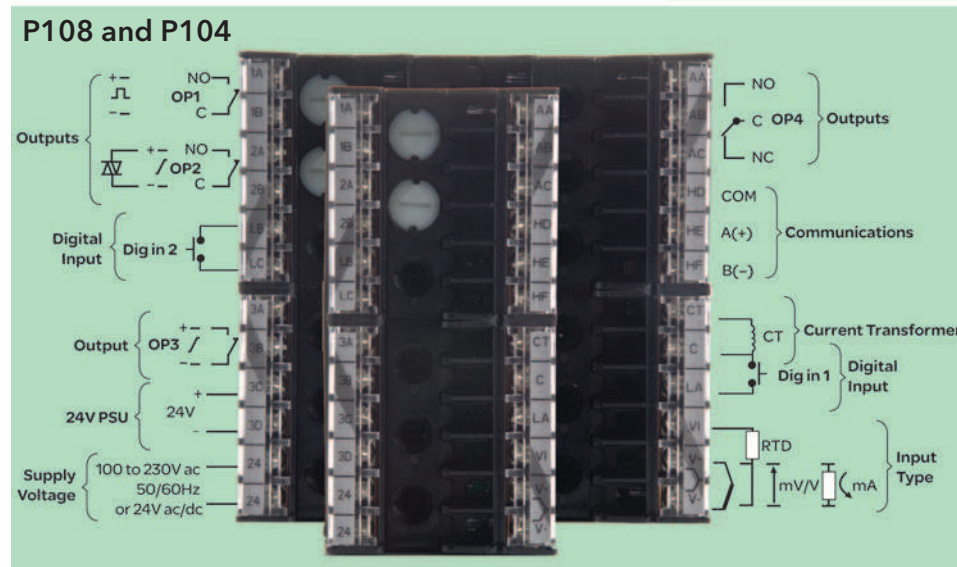
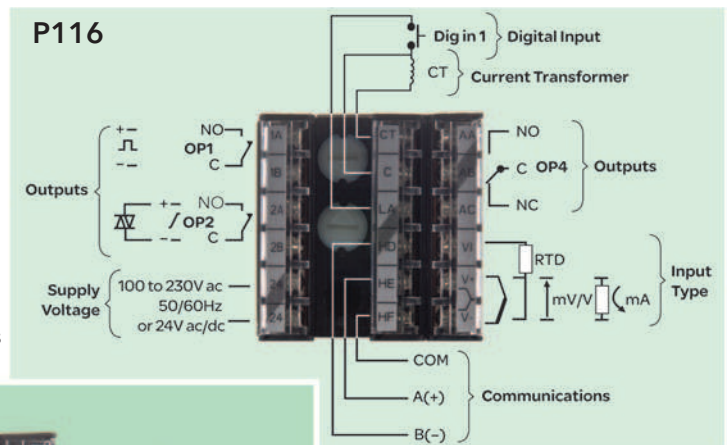

Real-world applications

Whether it's for excellence in control easy set up or easy straightforward functionality the piccolo controllers can be used across a broad range of applications to solve problems.



Kilns, Ovens and Furnaces

The piccolo controller is well adapted to ovens, small furnaces and kilns. For machines such as a small kiln for firing ceramics or an oven treating complex small parts, the timer function can gradually increase the temperature to the desired setpoint – preventing thermal shock or damage/distortion to the work pieces being heated.



The timer automatically maintains the temperature for the desired dwell period, before turning power off to allow the items to cool.

An over-temperature alarm may be used to control an interlock on the door as a basic safeguard.

All of this may be controlled either using the piccolo controller fascia, or from an external switch wired to an input on the controller.

Photograph courtesy of Wisconsin Oven

Batch Operation

The simple timer in the piccolo controller may be used to control batch operations, e.g. food ovens, sterilisers, fryers. Ideal for any application requiring a single dwell at the end of either a controlled ramp or natural approach to setpoint without the need for an additional timing device. This can also be used to automatically bring the process up to temperature ready for production to start in the morning.

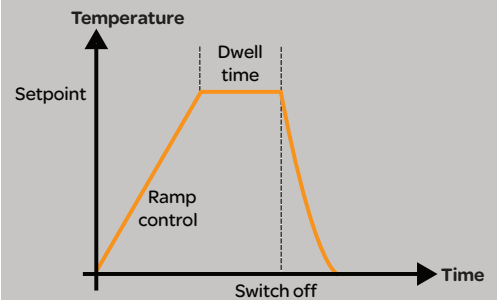

Plastic Processing Control (Extruders and Chillers)

Eurotherm has vast experience in Plastic Processing control and has helped improve the productivity of customers' single-screw, twin-screw, co-extrusion, or blown film systems by taking better control of the temperature.

Using low cost On/Off temperature controllers or poor PID controllers can result in variation of temperature in the feed throat, barrel and head which can ultimately lead to poor levels of productivity.

The precise PID control of the piccolo controller is used to ensure uniform heating of the material to avoid material degradation, undue strain on the extruder components, and improve process reliability.

Chillers are used in the plastics industry to protect valuable processing equipment – such as extrusion, injection moulding equipment and other applications. Another reason for their use is to increase production through constant and proper cooling temperatures in the equipment. A chiller will reduce the number of rejected parts while increasing the number of parts produced per hour.

A chiller is a compressor based cooling system that is similar to an air conditioner except it cools and controls the temperature of a liquid instead of air.

The piccolo controller can be used to consolidate functions and replace several interconnected devices to chillers, including an external timer. The level of functionality, programmability and alarming gives the user a way to create a local custom alarm strategy that can best achieve the operating safety of the machine, minimise downtime and improve quality.



Photograph courtesy of Welex



Photograph courtesy of Mokon

Photos displayed are purely to demonstrate applications that these controllers are suited to. Control systems on these specific units may differ from this product being offered

Practical functionality

Energy Saving

Energy saving in industrial processes is often as easy as increasing levels of thermal insulation around furnaces, boilers or pipes. If a working environment feels hot when you walk into it, the chances are that simple measures such as these will save considerable energy. However this can lead to control problems, because a well insulated system can be slow to react to cooling commands from the controller. The piccolo controller range has been designed to cope with such challenges and provide excellent performance even when there is a wide imbalance between the effects of heating and cooling.

Energy can also be wasted in providing headroom for heating because of control instability. If a process must maintain a temperature of a given level for a given 'soak' period of time, it is common to add in a safety factor on the temperature so that oscillations during the soak time don't take the temperature below specification. By using precise and accurate control, this safety factor may be reduced without risking expensive rework or scrap.



Energy Estimation

The aim of this function is to have an estimation of energy consumption of the controlled process. By setting the nominal power of your load with a dedicated parameter the instrument is able to calculate the integral of the on time period of a selected output. Two counters are provided in operative mode to offer a partial and a total counting feature. The purpose of this feature is to provide visual feedback on the energy being consumed. Any deviation observed from the average value will alert you to possible problems in the process.

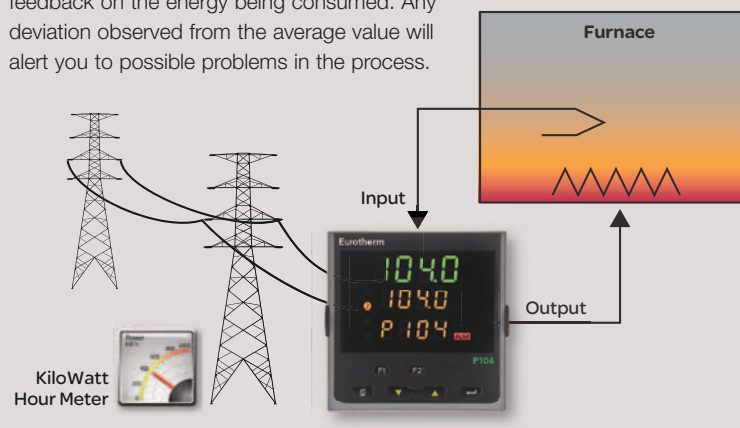

Heater Failure Detection

A current transformer input in the piccolo controller measures the current switched through the load. The measurement is filtered so that the on current and off currents can be separated. From this it is possible to diagnose several load faults including partial load failure, over current and an SSR fault. Typical applications include plastic extrusion, laboratory ovens and other applications where early indication of failure can help you to avoid product waste and allow you to plan your maintenance schedule.

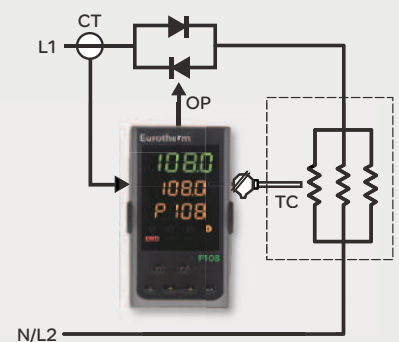

Undo Function

You wouldn't use a word processor without an undo function so why settle for less when working on control systems?



The piccolo controller undo function allows you to revert to a known instrument setting, either as supplied from the factory or a trusted setup. This enables you to experiment with settings and functions without the worry that you will lose the current configuration and have to recommission from scratch.

Overshoot Elimination

It is interesting to compare process control with the familiar situation of driving a car at a given speed. We tend intuitively to use full acceleration until we approach the speed we want, and then progressively back off acceleration until the speed is reached and regulate the speed around that point.

PID control typically works by gradually reducing power from a maximum over the full range of operation. This can cause a slower rise to setpoint, or can create overshoot and oscillations if the PID constants are set to allow more aggressive heating.

Cutback is a unique feature of the Eurotherm control algorithm and allows aggressive application of power outside a defined approach region. Just like a driver trying to reach a particular speed as fast as possible, the algorithm applies full power when the measured temperature is outside the region, before using PID control to make adjustments to the power within the cutback region only. This provides rapid response without overshoot or oscillations. This unique 'cutback' feature reduces process overshoot which in turn reduces startup time and hence allows processing to commence earlier.

The cutback function is automatically set up using the PID autotune facility in the piccolo controllers.

